



## INSTRUCTION MANUAL

ARG 200 plus • ARG 235 • ARG 235 plus  
ARG 260 • ARG 260 plus E • ARG 260 plus • ARG 300 F • ARG 300 plus F  
ARG 330 F • ARG 330 plus F



Pilous - pásové pily, spol. s r.o., Železná 9, 619 00 Brno, Czech Republic  
tel.: 00 420 543 252 010, e-mail: pilous@pilous.cz, www.pilous.cz



**Dear customer,**

thank you for purchasing our product. We wish you a lot of success with it in your business. Please pay close attention to the following instructions in order to ensure faultless operation of the machine.

© 2018 All rights, particularly the right to make copies of, to distribute and translate this instruction manual, are reserved. No part of this instruction manual may in any form (printing, copying, microfilm or other means) be reproduced or stored, processed, copied or distributed using electronic systems without a permission by PILOUS.

**Contents:****0. General**

- 0.1. Safety Provisions
- 0.2. Scope of Use / Use According to Designation
- 0.3. Requirements on operators
- 0.4. Machine requirements - Safety devices
- 0.5. Protective covers

**1. Transport and storage**

- 1.1. Surface Protection
- 1.2. Packing
- 1.3. Disassembly / Repacking
- 1.4. Disposal

**2. Technical Data****3. Installation**

- 3.1. Space requirements
- 3.2. Machine installation
- 3.3. Connection to the mains

**4. Machine description**

- 4.1. Control Panel
- 4.2. Oil Damper - Saw Blade Feed to the Cut
- 4.3. Mechanical Control of the Feed
- 4.4. Vice - Workpiece Clamping
  - 4.4.1. Adjustment Procedure - Lateral Play of the Vice
  - 4.4.2. Cutting Angle Settings
- 4.5. Saw Blade Guidance
- 4.6. Arm Back Cover Removal
- 4.7. Replacement, Tensioning and Adjustment of the Saw Blade
- 4.8. Guide Heads Adjustment
- 4.9. Cooling System

**5. Commissioning**

- 5.1. Security Check
- 5.2. Cutting Procedure

**6. Machine Maintenance**

- 6.1. Maintenance and Inspection
- 6.2. Repairs

**7. Failures - Potential Causes and Remedies****8. Saw Blades**

- 8.1. Saw Blade Design
- 8.2. Selection of Tooth Size
- 8.3. Optimum Workpiece Clamping
- 8.4. Running-in New Saw Blades
- 8.5. Factors Influencing Saw Blade Service Life
- 8.6. Values Recommended for Cutting

**9. Nameplate****10. Wiring Diagram**

- 10.1. ARG 200 Plus ,ARG 235, ARG 235 Plus, ARG 260 Plus E, ARG 260, ARG 260 Plus wiring diagram
- 10.2. ARG 235 Plus F, ARG 260 F, ARG 260 Plus F, ARG 300 F, ARG 300 Plus F, ARG 330 F, ARG 330 Plus F wiring diagram

**11. Assemblies**

- 11.1. Guide Head Assembly
  - 11.1.1. Guide Head Assembly in ARG 200 - 300
  - 11.1.2. Guide Head Assembly in ARG 330
- 11.2. Arm Assembly
  - 11.2.1. Arm Assembly in ARG 200 Plus
  - 11.2.2. Arm Assembly in ARG 235, ARG 260
  - 11.2.3. Arm Assembly in ARG 300
  - 11.2.4. Arm Assembly in ARG 330
- 11.3. Oil Damper Assembly
- 11.4. The Table, Turntable, Joint and Vice Assembly
  - 11.4.1. The Table, Joint and Vice in ARG 235 Assembly
  - 11.4.2. The Table, Joint and Vice in ARG 200 Plus, ARG 235 Plus ARG 260 Plus E Assembly
  - 11.4.3. Vice Assembly in ARG 200 Plus
  - 11.4.4. Vice Assembly in ARG 235, 235 Plus, ARG 260 Plus E
  - 11.4.5. The Table, Joint and Vice Assembly in ARG 260, ARG 300
  - 11.4.6. The Table, Turntable, Joint and Vice Assembly in ARG 260 plus, ARG 300 plus
  - 11.4.7. The Table, Joint and Vice in ARG 330 Assembly
  - 11.4.8. The Table, Turntable, Joint and Vice Assembly in ARG 330 plus
- 11.5. Cleaning Brush Assembly
- 11.6. Cooling Assembly
  - 11.6.1. Cooling Assembly in ARG 200 - 300
  - 11.6.2. Cooling Assembly in ARG 330

**12. Accessories**

- 12.1. Laser Guideline Light
  - 12.1.1. Activation and deactivation of the laser beam
  - 12.1.2. Laser Indication on the Machine
  - 12.1.3. Adjustment
- 12.2. Oil Mist Lubrication
- 12.3. Vertical Vice for VP Bundle Cutting

## 0. General

This instruction manual provides the user with assistance and information about the PILOUS metal-cutting band saw and the possibilities of use corresponding to its purpose. The instruction manual contains important instructions on a safe, adequate and economically efficient operation. Observing the operating instructions will prevent risks; the repair and outage time costs will be reduced and the machine reliability and life increased. The instruction manual contains instructions based on the valid national safety regulations and environmental standards. The instruction manual must be always available at the machine site. The instruction manual must be read and used by the staff entrusted with the machine installation, transport and storage, use / operation, maintenance and disposal. In addition to the instruction manual and binding safety regulations in force in the user's country and at the service site, it is also necessary to observe the approved rules for safe and professional work.

### Letter of Guarantee - Service

The Letter of Guarantee is a separate annex to the instruction manual.

Guarantee Period - see Letter of Guarantee Conditions for Maintenance of Claims under Guarantee

- Transport and storage of the machine in accordance with the instruction manual.
- Use and operation of the machine in accordance with the instruction manual.
- Connection of the machine to the power supply in accordance with the instruction manual.

### The guarantee does not apply to:

- Violent and mechanical damage of the machine caused by interference of the user or other persons.
- Inevitable events (natural disaster).
- Damage to the machine during transport.
- Storage or installation of the machine in humid, chemical or any other inappropriate environment.
- Wear parts (see the Letter of Guarantee).

**Potential claims concerning guarantee and after-guarantee repairs should be made by phone, post or e-mail to the address: see the Letter of Guarantee.**

### Note for the User:

The Seller is obliged to hand over to the User the Letter of Guarantee immediately with the purchase of the product. The Letter of Guarantee must be properly and legibly filled out and confirmed by the Seller's stamp, signature and date of purchase. The Seller is obliged to inform the Buyer about the use and handling of the product.

### Data Necessary for Claiming Guarantee (After-Guarantee) Repair:

- Machine type
- Letter of Guarantee Number (identical with the serial number of the machine)
- Date of issue of the Letter of Guarantee

## 0.1. Safety Provisions

The machine design complies with the technical status and the approved safety and technical rules. In spite of this, the user's or the third persons' health can be endangered and/or the machine or other tangible goods may be unfavorably influenced during the operation of the machine. In order to prevent such hazards, it is absolutely necessary to observe the safety instructions in this instruction manual. These safety instructions must be read and understood by the respective persons before the machine has been put into operation. Failure to observe these instructions may lead to serious health and property damage! The safety instructions in this instruction manual are marked with safety symbols / danger spot signs.



**Warning: Dangerous spot -  
Use the highest caution!**



**Caution: Dangerous voltage!**



**Use protective goggles!**



**Health hazard by flying particles!**



**Use hearing protection!**



**Danger of injury by compression!**



**Use boots or work shoes with a steel toe.  
And with anti-slide soles.**



**Danger of injury by cutting!**



**Use protective gloves!**



**Before using the bandsaw, read this instruction manual carefully and make sure you understand its content!**

## 0.2. Scope of Use / Use According to Designation

The machine is intended solely for cutting (primarily metal) workpieces. Any other use is considered as inadequate to the purpose. The manufacturer is not responsible for damages arising from such use, the risk is borne by the user alone. The use complying with the purpose includes also observing the operating instructions and the check and maintenance conditions.

**Examples of materials that can be cut:** structural steel cementing steel nitriding steel free-cutting steel heat-treated steel roller bearing steel spring steel tool steel high-speed steel cast steel cast iron copper brass aluminium plastics.

Consider the recommendations for use as prescriptive values. In case of special cases, consult the manufacturer.

## 0.3. Requirements on operators

**The machine may only be operated by persons that have been appropriately trained and instructed in safety at work!**

The machine may only be operated if it is in perfect condition with respect to technical safety. The user is obliged to check the machine for visually detectable damages and faults at least once per shift. Immediately report to your manager any damages and faults on protective devices and changes in the operation of the machine that threaten safety. No safety devices may be removed, moved, put out of operation or changed during the machine operation. Otherwise any warranty claims shall be null and void! If any safety device has to be removed during operation or maintenance, secure the main switch in the „OFF" position by a padlock or disconnect the machine from the mains and secure it against restart.

- Remove loose parts of clothes, cover long hair.
- Make sure that all other persons stand or move at least 2 meters from the saw blade, protect them from flying chips and prevent harm to them in case the saw blade breaks.  
All persons helping you at the site must be made familiar with all the safety rules.
- The safety rules must be provided on a visible place at the site.
- Keep hands at a safe distance from the saw blade; never adjust the device when the motor is running. Switch off the motor and secure it against restart before you start handling the saw blade.



**Only persons with adequate electrician qualifications are allowed to open protective covers of the electrical equipment and to work on it.**

## 0.4. Machine requirements - Safety devices

### Danger of Injury!



**No cover on the saw blade in the cutting area! High risk of injury in the operating area of the arm! Before you open protective devices, wait until the saw blade and the grinding wheel stop.  
Never use the sharpener when you are tired, exhausted, under the influence of medicaments, drugs or alcohol!**

Horizontal metal band saw is a cutting machine equipped for saw blade cutting. In order to complete the manufacturing process, the grinding wheel must reach the saw blade in the machining area. You can install the protective covers against contact with the saw blade only outside the machining area.

## 0.5. Protective covers

The saw blade and its wheels are protected against contact outside the machining area. You can remove protective covers only if the power switch is turned off and secured against restart or if the machine is disconnected from the mains and the saw blade is still. Before leaving the band saw, all covers must be closed. The protective cover of the arm and the wheels with the saw blade are secured by an end switch. If the covers is not completely closed, none of the machine's drives will start.

To stop the machine in case of emergency, press TOTAL STOP button. You can put the machine back to operation only after you manually unlock the switch by turning it clockwise. Fixed and movable bars of guide heads are fitted with solid protective covers that protect the area outside the machining area.



**Manual cleaning and removal of waste when the machine is working or running down is prohibited. A first-aid kit must be available at the workplace. You have to wear suitable work clothes, shoes and adequate protective equipment (eye protection, hearing protection, gloves, steel-toed work shoes) at work. Observe valid health rules concerning the air quality at the workplace.**

## 1. Transport and storage

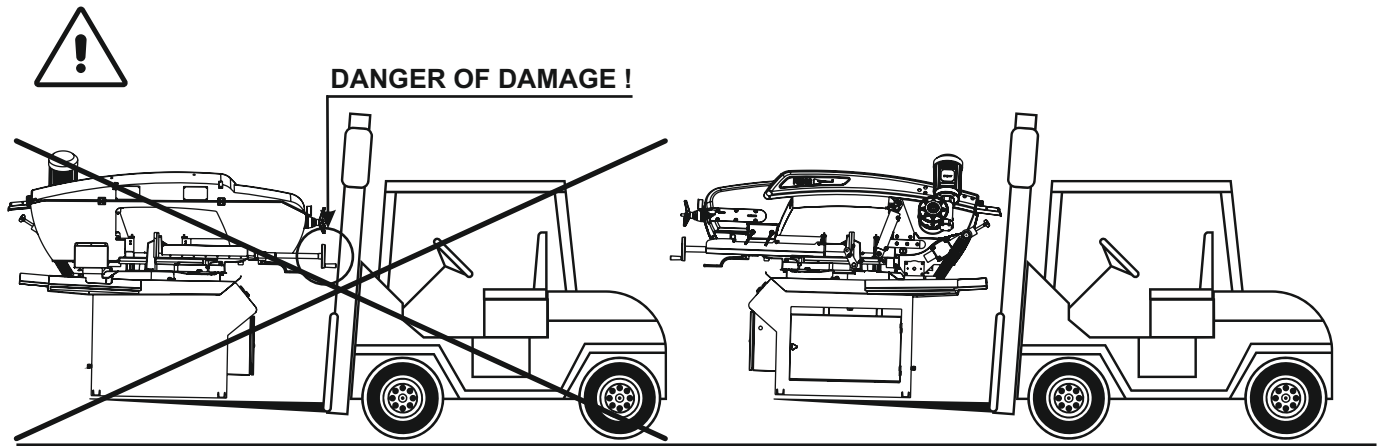

**You can transport and lift the machine only with a forklift. THE USE OF A CRANE PROHIBITED!**

### 1.1. Surface Protection

Machine parts are protected against corrosion by powder coating or a primer and two-component polyurethane varnish. Sliding surfaces are coated with anti-corrosive oil. Surfaces of other parts and components of the machine are treated by galvanization or blackening.

### 1.2. Packing

The basic feature of the package is a wooden frame, which can take the form of wood cladding or an overseas case. The distance between the package and the floor is approximately 100 mm, which enables handling by a forklift. The machine is packed in a stretching foil that protects it against weather influence during transport.

#### Standard accessories:

- 1 pc. metal saw blade, bimetal M42 (mounted),
- 1 pc. band saw instruction manual,
- 1 length stop.

### 1.3. Disassembly / Repacking

Disconnect the machine from the mains empty and clean the metal chip tank and the coolant tank clean the machine apply anticorrosive oil on the sliding surfaces fix the arm for transport lift the machine and screw on the wooden frame observe the distance of approximately 100 mm from the ground for the transport with the forklift make sure that all protective covers of the machine are in place and fastened add the machine accessories.



**Caution: used coolants belong to the category of special waste!  
Only a person with adequate electrician qualifications can disconnect the machine from the mains!**

### 1.4. Disposal

When the machine has been definitely put out of operation, it should be disposed of in accordance with the provisions valid in the respective country. We recommend that you contact a specialist waste disposal service.

## 2. Technical Data

**Machine noise** - measured in conformity with ČSNEN ISO 3746:2011

The acoustic pressure level at the workplace: 76 dB (A), acoustic power level: 91 dB (A).

The measured values exceed the value specified in the Government Regulation No. 176/2008, section 1.7.4.2, article u) and therefore ear protection must be used during the machine operation. The measurement was carried out while the machine was in a steady state and the saw blade speed was 80m/min. During the operational state with a technical load, the most frequently used technological process was measured. Noise levels measured on the machines may vary depending on the type of cut material, saw blade speed and other factors.

		ARG 200 plus	ARG 235	ARG 235 plus	ARG 260	ARG 260 plus E
MAIN MOTOR		400 V, 50 Hz 0,75 / 0,95 kW	400 V, 50 Hz 0,9 / 1,4 kW	400 V, 50 Hz 0,9 / 1,4 kW	400 V, 50 Hz 0,9 / 1,4 kW	400 V, 50 Hz 0,9 / 1,4 kW
MAIN MOTOR version F						
PUMP MOTOR		400 V, 50 Hz 0,05 kW	400 V, 50 Hz 0,05 kW	400 V, 50 Hz 0,05 kW	400 V, 50 Hz 0,05 kW	400 V, 50 Hz 2,2 kW
SAW BLADE SPEED		40 / 80 m/min	40 / 80 m/min	40 / 80 m/min	40 / 80 m/min	40 / 80 m/min
SAW BLADE SPEED version F						15-90 m/min
CUTTING ANGLE RANGES	[mm]	 90°  45°  60°	 90°  45°  60°	 90°  45°  60°	 90°  45°  60°	 90°  45°  60°
	∅	200 135 155 95	235 185 115	235 185 165 115	260 200 125	260 200 180 125
	a a <sub>a</sub>	200 115 130 65	230 160 80	230 160 145 80	255 185 120	240 185 160 105
	a×b	250×140 150×70 160×125 100×60	280×180 185×100 115×80	280×180 185×100 185×80 115×80	300×200 185×200 125×120	300×185 185×195 190×105 125×105
ARM SWING		 90°  60°  45°	 90°  60°  45°	 90°  60°  45°	 90°  60°  45°	 90°  60°  45°
SAW BLADE SIZE		2490×20×0,9	2710×27×0,9	2710×27×0,9	2880×27×0,9	2880×27×0,9
SAW BLADE RUNNER WHEELS DIAMETER		300 mm	300 mm	300 mm	310 mm	310 mm
VICE OPERATING HEIGHT		900 mm	900 mm	900 mm	910 mm	900 mm
OIL IN THE HYDRAULICS		Hydraulic oil Olea OPTIMA HV 46	Hydraulic oil Olea OPTIMA HV 46	Hydraulic oil Olea OPTIMA HV 46	Hydraulic oil Olea OPTIMA HV 46	Hydraulic oil Olea OPTIMA HV 46
COOLANT TANK		approximately 15 litres	approximately 15 litres	approximately 15 litres	approximately 15 litres	approximately 15 litres
MACHINE WEIGHT		255 kg	265 kg	285 kg	335 kg	300 kg

		ARG 260 plus	ARG 300 F	ARG 300 plus F	ARG 330 F	ARG 330 plus F
MAIN MOTOR		400 V, 50 Hz 0,9 / 1,4 kW				
MAIN MOTOR version F		400 V, 50 Hz 2,2 kW	400 V, 50 Hz 2,2 kW	400 V, 50 Hz 2,2 kW	400 V, 50 Hz 3 kW	400 V, 50 Hz 3 kW
PUMP MOTOR		400 V, 50 Hz 0,05 kW	400 V, 50 Hz 0,05 kW	400 V, 50 Hz 0,05 kW	400 V, 50 Hz 0,12 kW	400 V, 50 Hz 0,12 kW
SAW BLADE SPEED		40 / 80 m/min				
SAW BLADE SPEED version F		15-90 m/min	15-90 m/min	15-90 m/min	15-90 m/min	15-90 m/min
CUTTING ANGLE RANGES	[mm]	 90°  45°  60°	 90°  45°  60°	 90°  45°  60°	 90°  45°  60°	 90°  45°  60°
	∅	260	300	300	330	330
	a	255	290	290	320	320
a x b	300x200	375x190	375x190	400x200	400x200	400x200
ARM SWING		185x200	240x160	240x100	250x170	250x140
SAW BLADE SIZE		2880x27x0,9	3150x27x0,9	3150x27x0,9	3870x34x1,1	3870x34x1,1
SAW BLADE RUNNER WHEELS DIAMETER		310 mm	355 mm	355 mm	420 mm	420 mm
VICE OPERATING HEIGHT		910 mm	910 mm	910 mm	940 mm	945 mm
OIL IN THE HYDRAULICS		Hydraulic oil Olea OPTIMA HV 46	Hydraulic oil Olea OPTIMA HV 46	Hydraulic oil Olea OPTIMA HV 46	Hydraulic oil Olea OPTIMA HV 46	Hydraulic oil Olea OPTIMA HV 46
COOLANT TANK		approximately 15 litres	approximately 15 litres	approximately 15 litres	approximately 35 litres	approximately 35 litres
MACHINE WEIGHT		480 kg	420 kg	570 kg	665 kg	720 kg



### 3. Installation

#### 3.1. Space requirements

You can install the machine on any suitable and even floor (concrete) in a factory hall. Observe the allowed floor load. Remove the wooden frame. Set the machine on the place designated for use. Level the machine with washers (not included in the shipment). Remove the anticorrosion film and dust from sliding surfaces and apply oil. Attach the length stop. Ensure connection to the mains (see section 3.3.). After you open the door in the machine base, check whether the outlet coolant pipe has not fallen out of the coolant tank cover and is fitted well inside. Pour the coolant (approximately 15/35 litres, see the Technical Data) into the tank; the fluid will gradually flow into the container in the base. Fasten the lifting lever with screws in the holes in the grey cast iron arm as shown in the picture in Section 4. Machine description.



**When handling coolants, risks linked to hazardous substances cannot be avoided. Observe the national norms and recommendations and manufacturer's or your company's operating instructions related to safe handling of coolants.**

#### Recommendations/requirements:

- Allow for sufficient space for the feeding and removal of the workpiece and the machine maintenance - the operator's working area should be delineated at 1 m minimum around the machine and 0.5 m around the roller conveyors.
- Install roller conveyors and/or a case for cut pieces collection for a safe handling of workpieces and to prevent accidents due to pieces falling off.
- We recommend that you anchor the machine to the floor, especially when installing the roller conveyors.
- Install a lift mechanism for heavy workpieces.
- Ensure proper lighting at the workplace.

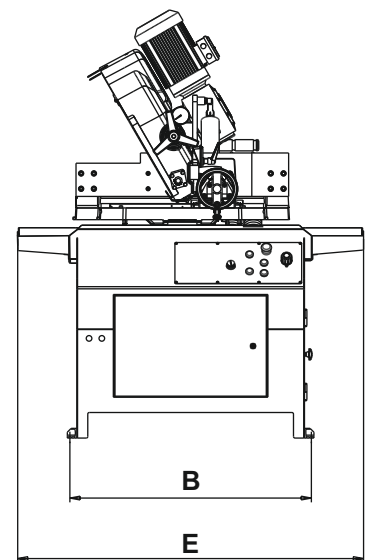
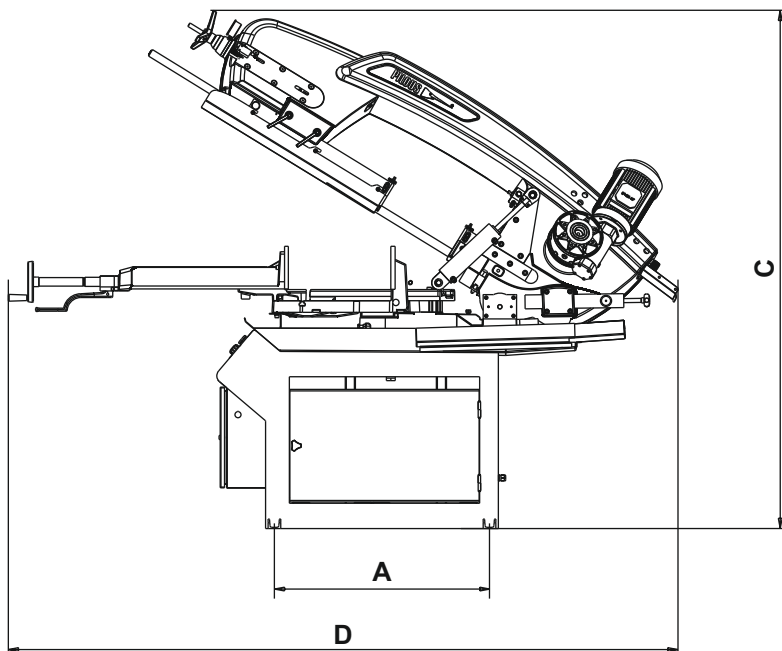
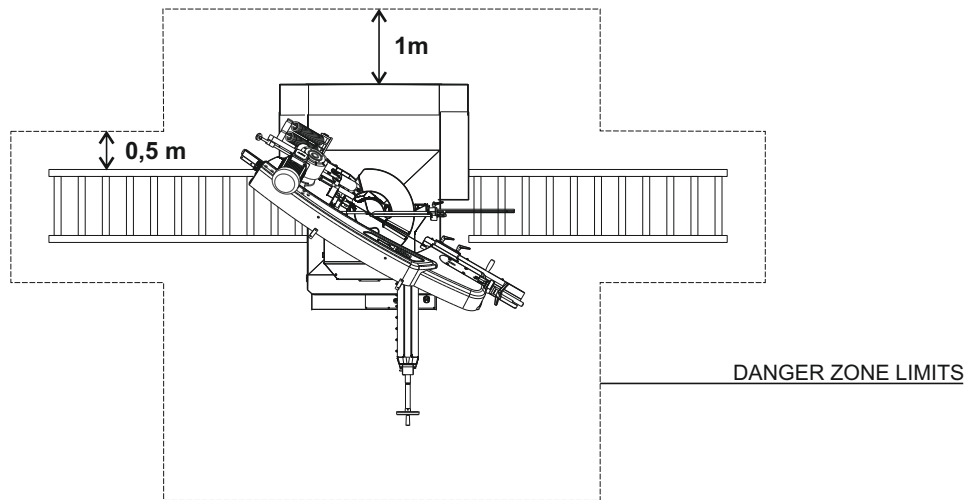

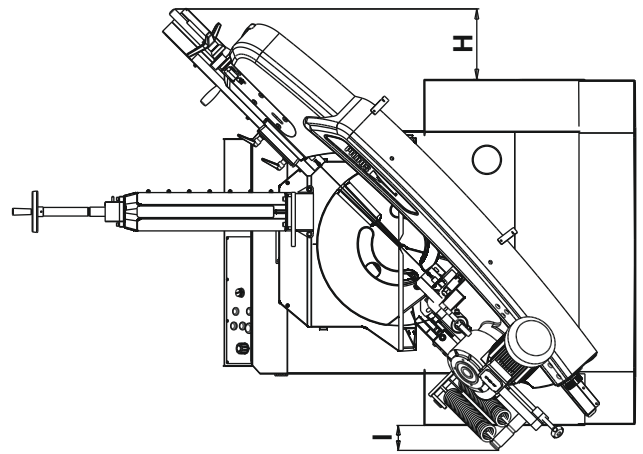
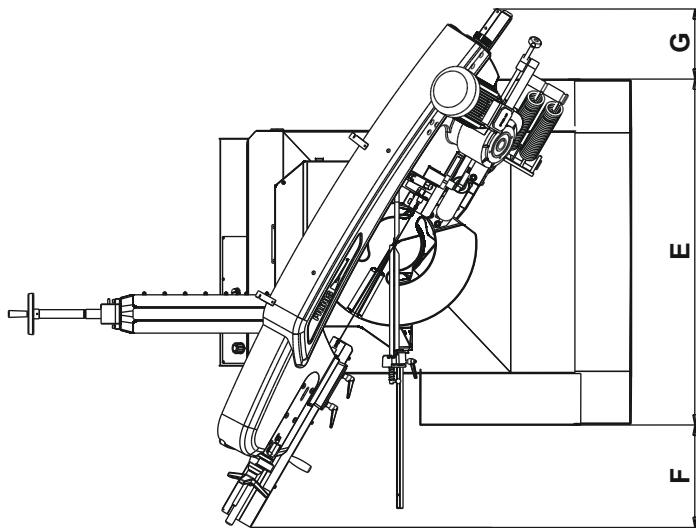

	ARG 200 plus	ARG 235	ARG 235 plus	ARG 260	ARG 260 plus E	ARG 260 plus	ARG 300 F	ARG 300 plus F	ARG 330 F	ARG 330 plus F
A	796	796	796	796	796	850	1050	850	850	850
B	640	640	640	640	640	945	648	945	945	945
C min	1400	1400	1400	1440	1420	1420	1560	1560	1660	1660
C max	1980	2000	2000	2030	2040	1980	2030	2050	2060	2050
D min	1450	1680	1640	1700	1660	1620	1760	1740	2290	2290
D max	1430	1870	1930	1960	1980	1860	2180	1840	2660	2650
E	750	750	750	750	750	950	890	950	1360	1360
F	430	560	550	550	570	410	660	580	400	410
G	100	160	160	200	190	150	110	160	280	290
H	190	x	310	x	310	270	x	340	x	270
I	110	x	110	x	140	x	x	130	x	70

C min - the arm is lowered  
C max - the arm is raised

D min - the arm is lowered, the vice is closed  
D max - the arm is raised, the vice is opened

### 3.2. Machine installation



**Protect the machine against humidity, rain and dust!**

The machine may be operated in the ambient temperature between + 5° and + 40°C. The average air temperature must not exceed + 35°C within 24 hours. In temperatures below + 5°C the conventional coolants should be replaced by coolants designed for such temperatures.

### 3.3. Connection to the mains



**Such operations must be carried out only by persons with electrician qualifications!**

Make sure that the grid voltage, the voltage protection and the connection voltage comply with the power requirements specified in the point 2. Technical parameters. When connecting the machine to the mains (3 NPe 50 Hz, 400 V, TN-S), **mind the colour coding of wires carefully: L1 brown, L2 black, L3 gray, N blue, PE yellow-brown. Improper connection of the neutral or PE wires may lead to damage of the electrical equipment or to an electric shock!** Connect the power cable to a protected **16 A** socket, in case of direct connection to the mains, it is necessary to fit the supply with a lockable master switch. If the motor rotates in an incorrect direction, swap the conductors **L1 brown and L2 black** on the junction box.



**Failure to observe the aforementioned may lead to incorrect rotation of the bandsaw and the coolant pump. Danger: Damage to the machine!**

## 4. Machine description

Gravity self-feeding metal-cutting band saws allow for cutting of a wide range of different materials. The arm uplift, workpiece feed, clamping and removal of workpieces are carried out manually. A welded metal saw blade serves as the cutting tool. The saw blade is mechanically tensioned on the blade wheel. It is powered by an idler wheel that is powered through a work gearbox by a motor. In the machining zone, the saw blade is guided through the saw blade guide heads. Outside the machining zone the saw blade is protected by moving and fixed guards.

<b>A</b> arm	<b>H</b> turntable	<b>N</b> quick-clamping lever
<b>B</b> saw blade	<b>I</b> base	<b>O</b> solid bar
<b>C</b> saw blade tensioning	<b>J</b> coolant tank with pump	<b>P</b> moving bar
<b>D</b> gearbox	<b>K</b> control panel	<b>Q</b> angular scale
<b>E</b> motor	<b>L</b> arm swing locking lever	<b>R</b> end switch
<b>F</b> oil damper	<b>M</b> movable bar clamping lever	<b>S</b> lifting lever
<b>G</b> vice		<b>T</b> switchboard

**ARG 200 plus**

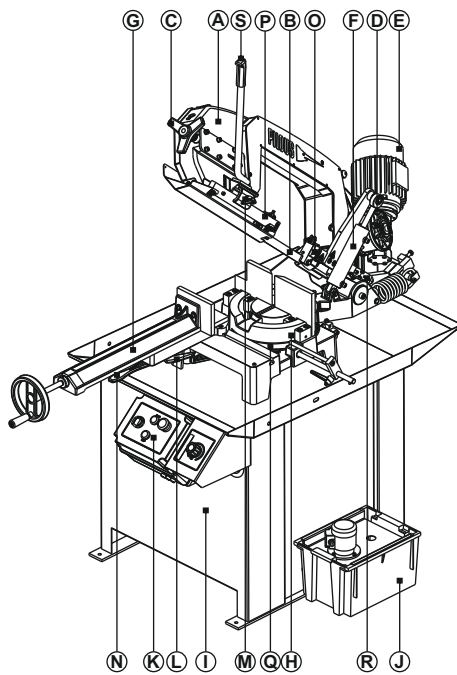

**ARG 235 plus, ARG 260 plus E**

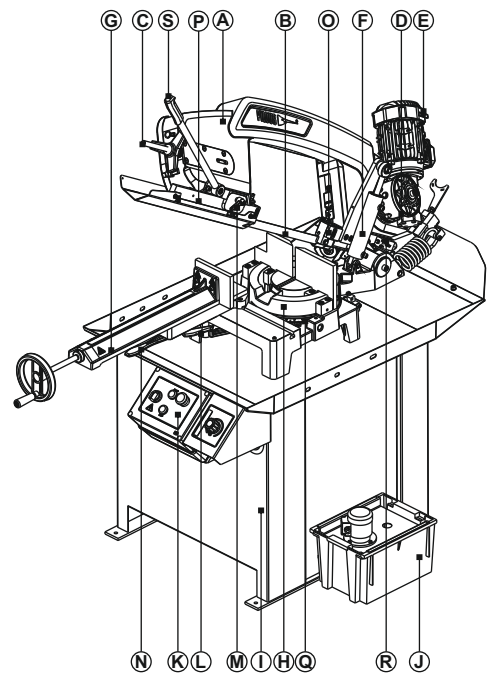

**ARG 235, 260, 300, 330**

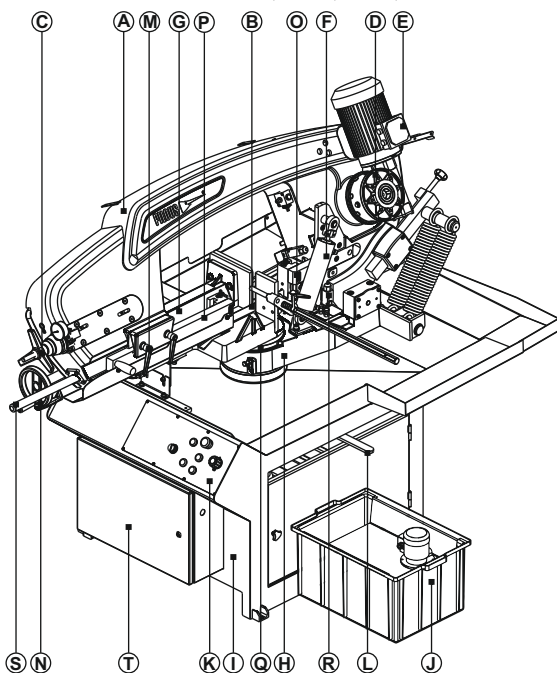

**ARG 260 plus, 300 plus, 330 plus**

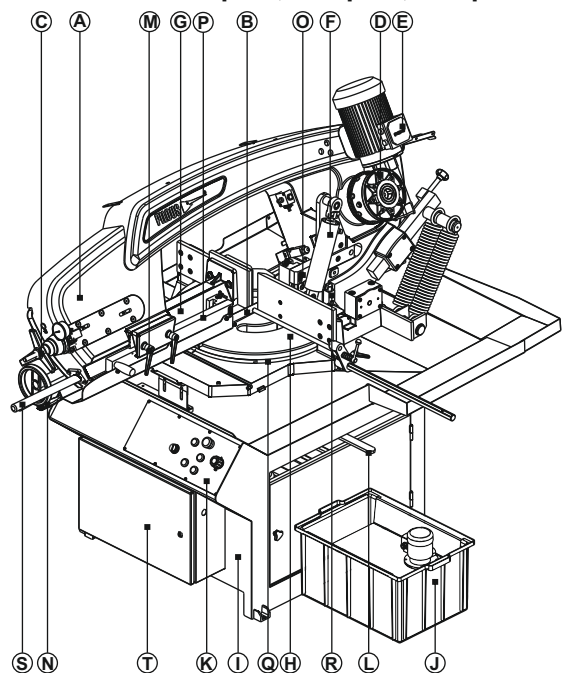

## 4.1. Control panel

Control panel in ARG 200 plus, ARG 235, ARG 235 plus, ARG 260, ARG 260 plus E

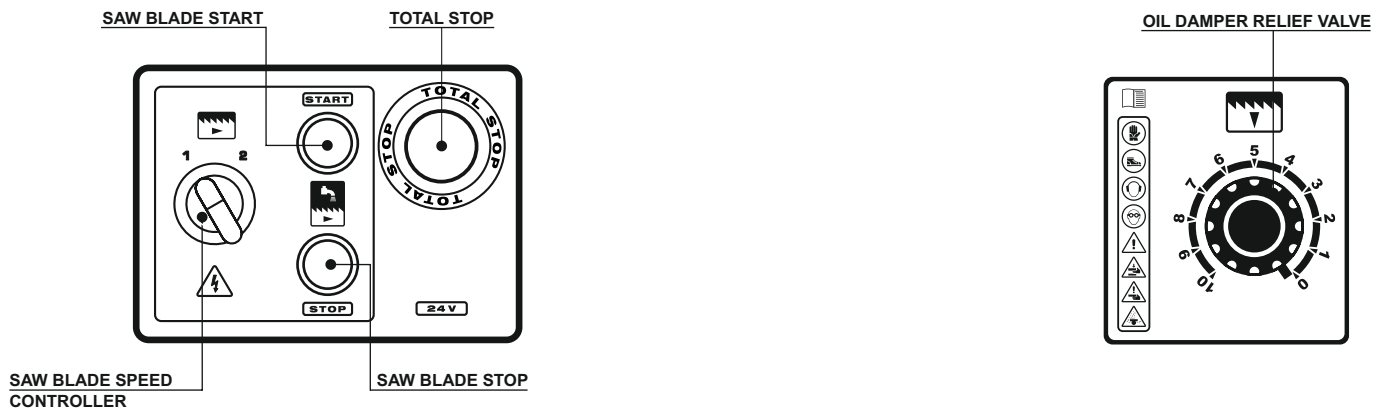

### Control panel ARG 260 plus

SAW BLADE SPEED CONTROLLER placed on the switchboard

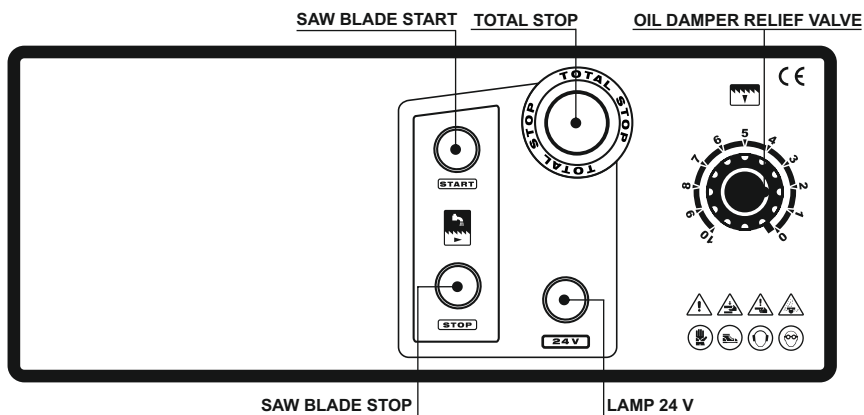

### Control panel ARG 300 F



### Control panel ARG 260 plus F, ARG 300 plus F, ARG 330 F, ARG 330 plus F

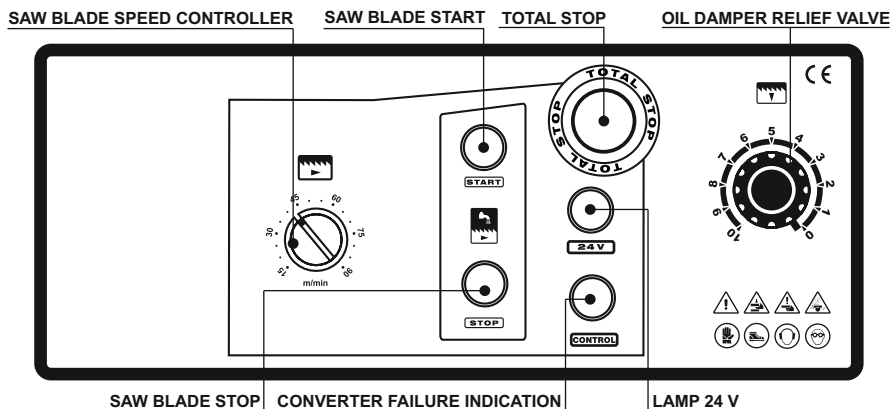

## Basic functions

### MAIN SWITCH



Only the F version - frequency converter.

Placed on the switchboard.



**Before you start the saw blade motor, always make sure that the saw blade is not in contact with the workpiece at the point of cutting.**

### TOTAL STOP



Ensures emergency stop of the saw blade motor and coolant pump. You can put the machine back to operation only after you manually unlock the switch by pulling or twisting!  
**CAUTION - Upon pressing the switch, the arm keeps on descending - DANGER OF INJURY!**

### SAW BLADE START - STOP



START



STOP

**Green START button** - starts the saw blade motor and the coolant pump.

When starting the saw blade motor, the arm has to be raised above the switching track of the limit switch that ends the cut. Otherwise the motor will not start.

**Red button STOP** - stops the saw blade motor and the coolant pump.

**CAUTION - Upon pressing the switch, the arm keeps on descending - DANGER OF INJURY!**

### SAW BLADE SPEED CONTROLLER (only 2 speed version)

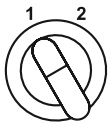

Use the controller on the control panel on the base of the saw to change between cutting speeds.

1 - 40 m/min  
2 - 80 m/min



**Caution: Change the cutting speed only if the motor is stopped (the saw blade is still).**

### SAW BLADE SPEED CONTROLLER (only the F version - frequency converter)



Use the controller on the control panel on the base of the saw to change between cutting speeds.

15 - 90 m/min

### LAMP 24 V



The lamp is on if voltage of 24 V flows to the control panel.

### CONVERTER FAILURE INDICATION



The red lamp is on - frequency converter failure (see Section 7).

## 4.2. Oil Damper - Saw Blade Feed to the Cut

The oil damper relief valve allows for a continuous setting of the velocity of saw blade feed towards the cut or stabilizing the saw arm in any position by mechanical closing. The optimum value of descent can be determined very easily by ear. The saw blade movement must be noiseless, free from vibrations. Such a state can be achieved by reducing or increasing the pressure force (by the velocity of saw arm descent). The prerequisite of setting the optimum pressure is selecting the correct saw blade velocity and the optimum size of the saw blade teeth.

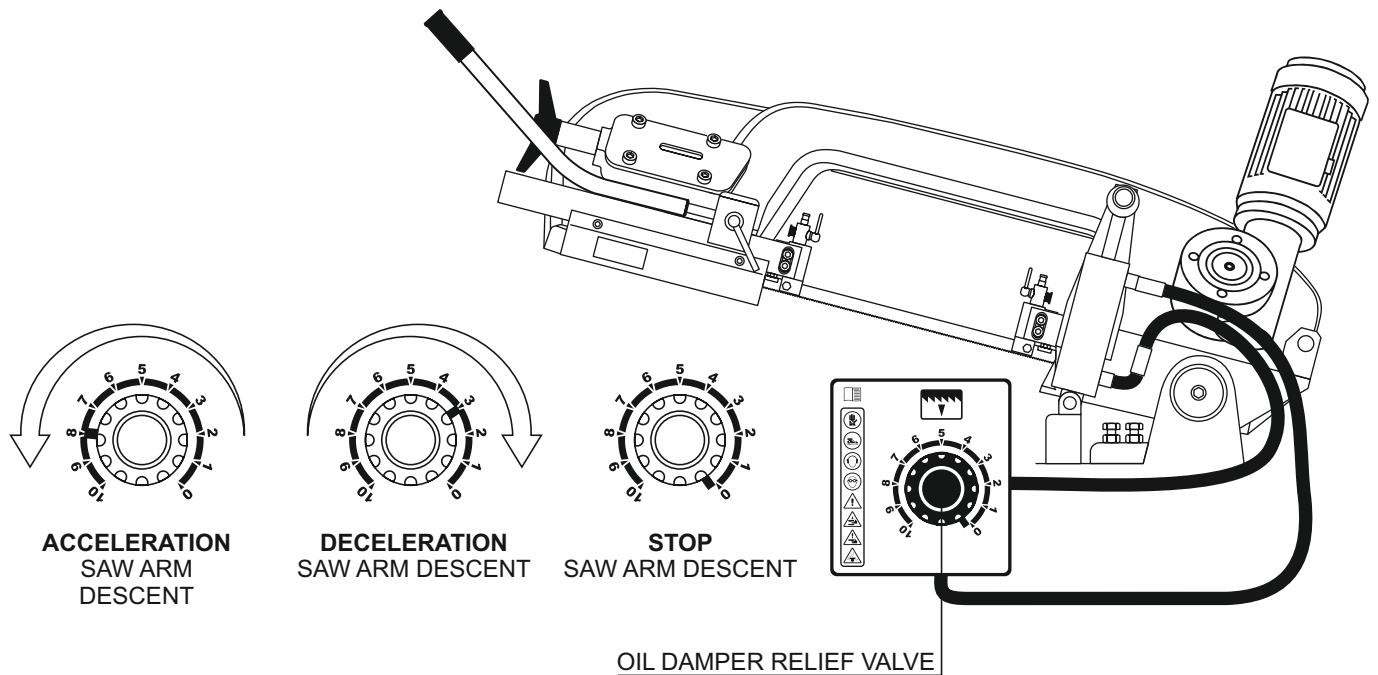

## 4.3. Mechanical Control of the Feed

The springs are pre-tensioned during the manufacture for a universal use, during which the arm smoothly rises and descends with a force ration ideal for most applications. Especially when cutting sturdy full materials, it is useful to increase the blade feed using the weight of the cast iron arm. This is facilitated by continuous loosening of the adjusting screw and pulling down of the springs. If cutting only thin-walled sectional construction materials, it is, on the contrary, possible to pull up the springs by screwing-in the adjusting screw, which leads to a smaller blade feed to the cut and, in particular, easier arm uplift. The adjusting screw moves easily in the position, in which the arm is raised and the springs are not tensioned.

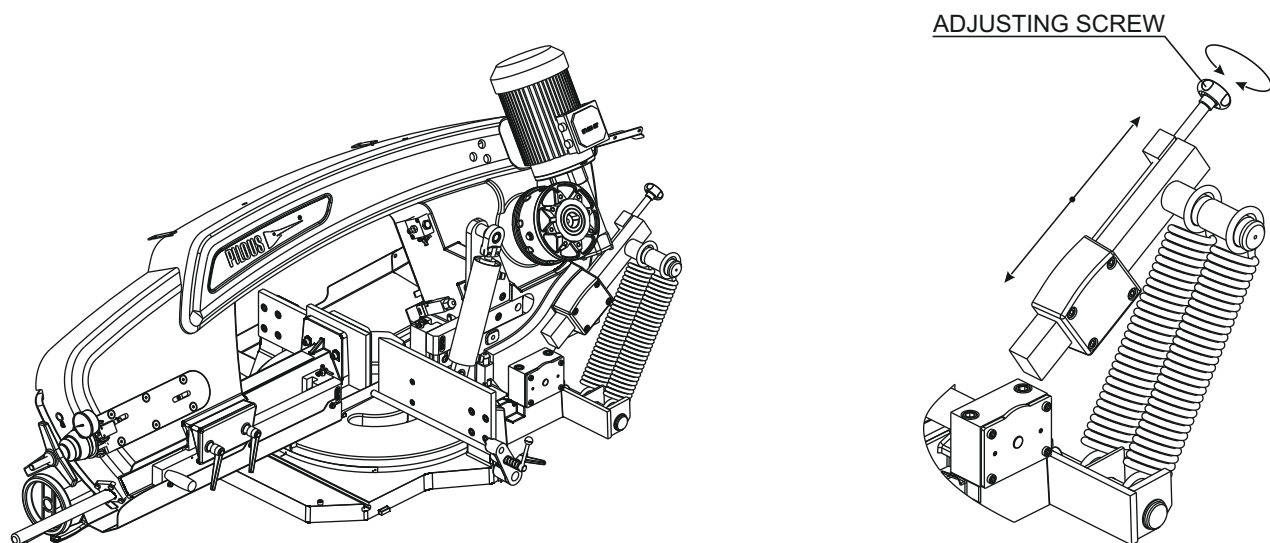

## 4.4. Vice - Workpiece Clamping

The design of the machine allows for angular cutting without a need to handle the workpiece. The workpiece lies between the fixed clamping jaw and a movable clamping jaw. To set the desired cutting angle, swing the entire arm and the turntable after releasing the arm swing locking lever. After you set the desired angle (based on the angular scale), the turntable with the arm will lock using the arm swing locking lever. The stop screws facilitate a permanent setting of limit angles. See the **FIXED ARM SWING STOP** in Section 4.4.2. In certain saw types (ARG 235 - 330 plus F), when cutting workpieces of the same diameter, the quick-clamping lever allows release and subsequent workpiece clamping without the need to use the handwheel. Mind the loading of the workpiece parallel with the fixed jaw of the vice. The quick-clamping lever and the handwheel cannot be used for corrections of wrongly placed long workpieces in the vice, otherwise you risk a damage to the machine. In the types marked with **PLUS**, upon loosening the setting screws, the movable part of the vice moves along the "T" groove to the left or right depending on the arm swing angle. Check whether the workpiece is properly clamped, otherwise you risk its ejection during cutting!

### **ARG 235, ARG 260, ARG 300 F, ARG 330 F**

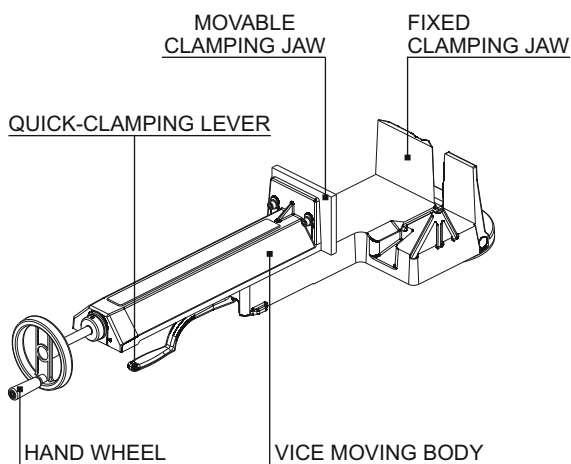

### **ARG 235 plus, ARG 260 plus, ARG 300 plus F, ARG 330 plus F**

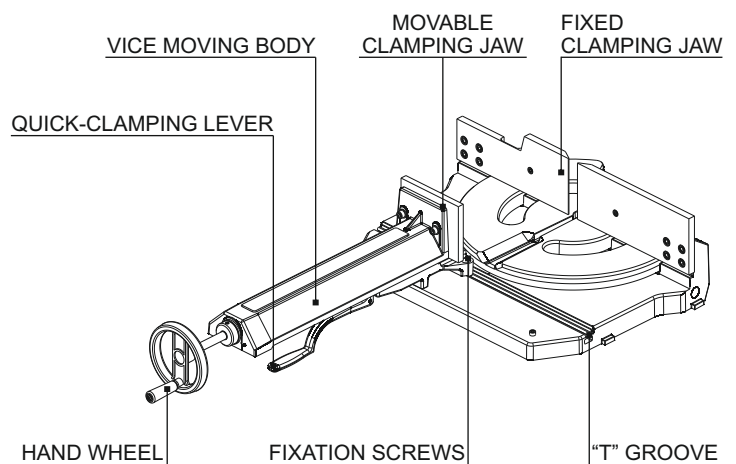

### 4.4.1. Adjustment Procedure - Lateral Play of the Vice

You can adjust the lateral play of the vice in all types of saws:

- ① Open the movable vice jaw to maximum extent.
- ② Loosen the M8 LOCKING NUTS and loosen the M8 VICE PLAY SETTING SCREWS.
- ③ Carefully tighten the first VICE PLAY SETTING SCREW (right at the movable clamping jaw) up to a point, where you feel that the screw (through a supporting ball) rested on the bar that pushes to the groove.
- ④ In this position, tighten the screw with an M8 LOCKING NUT against loosening.
- ⑤ Use the handwheel to move the VICE MOVING BODY, so that the next VICE PLAY SETTING SCREW is in the same position as the previous screw.
- ⑥ Repeat points ③, ④, ⑤ until the vice is completely closed and therefore adjusted.

You can watch the video with instructions on [www.pilous.cz](http://www.pilous.cz).

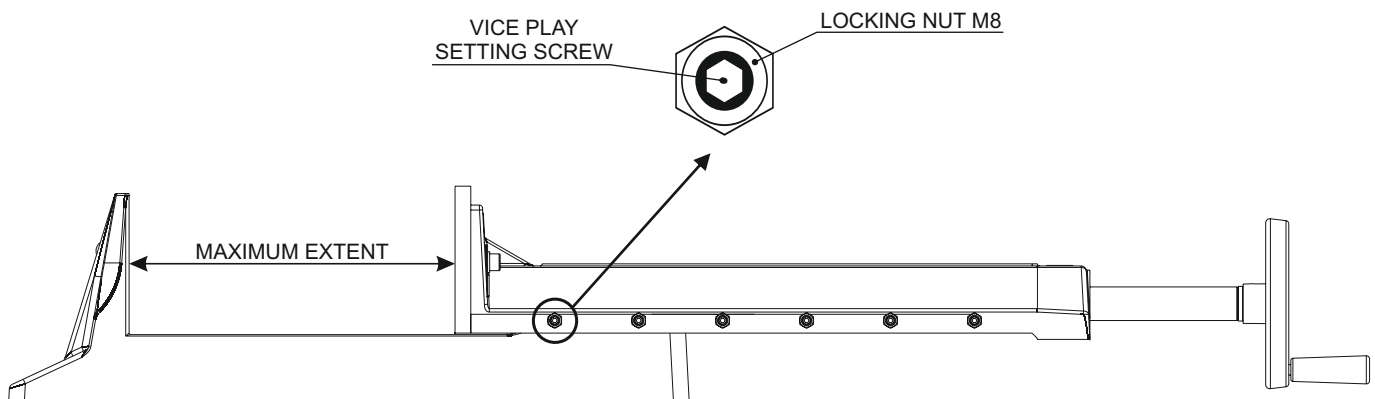

### 4.4.2. Cutting Angle Settings

#### **ARG 200 plus, ARG 235 plus, ARG 260 plus E**

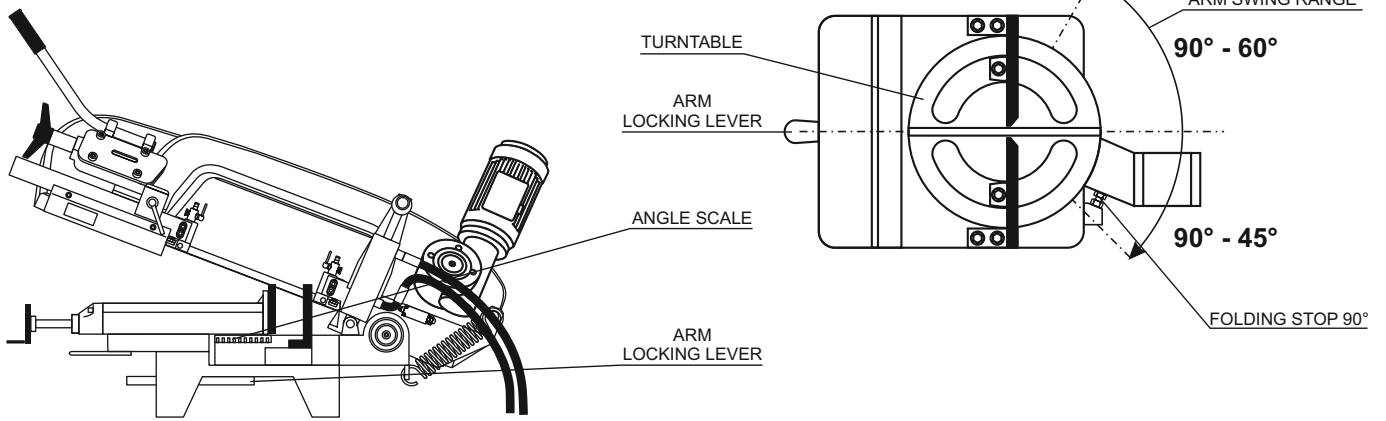

#### **ARG 260, ARG 300, ARG 330**

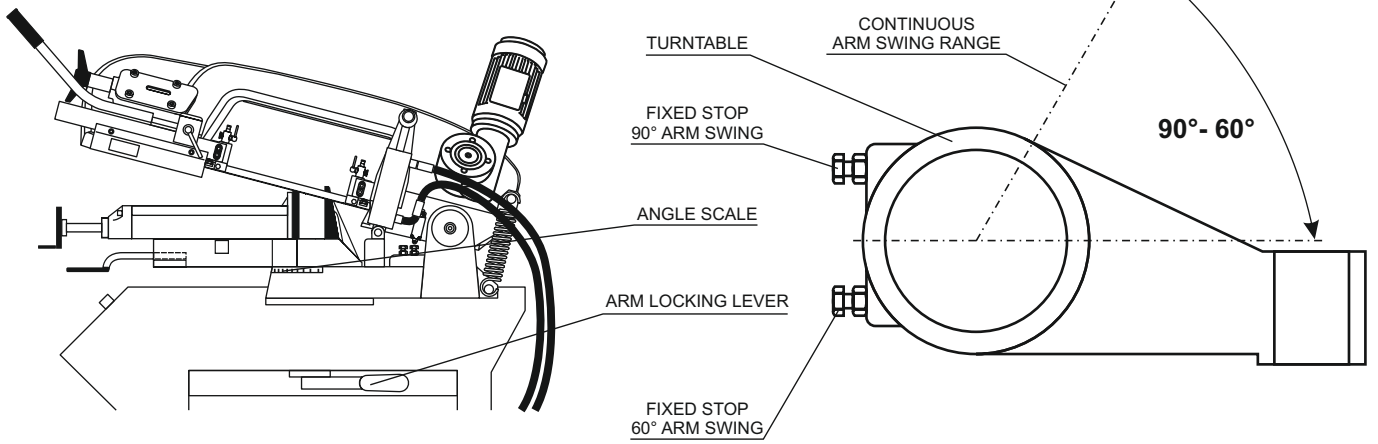

#### **ARG 260 plus, ARG 300 plus, ARG 330 plus**

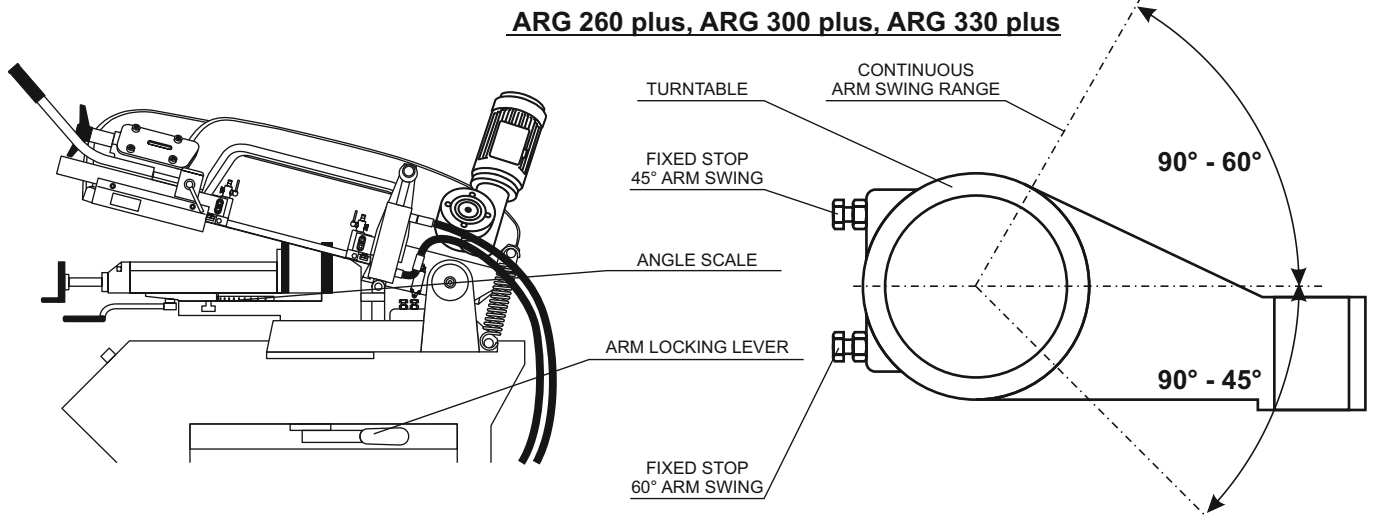



ARG band saws allow for both perpendicular cuts and cuts up to 60 °. Band saws marked with PLUS allow for double-sided continuous cutting angle settings within 60 ° to the right and 45 ° to the left. Before you swing the arm, unlock the arm with the locking lever and after setting the desired angle, lock the arm again. The desired arm swing angle will subtract from the angle scale. In the PLUS version, before you swing the arm, mind the correct vice positioning in relation to the desired swing angle in order to prevent a collision of the arm/blade with the vice. If there is a danger of collision, loosen the adjusting screws of the vice and move the vice in the T groove to the other side, while the arm is raised, and lock the vice again. When swinging the arm in machines swingable to one side only, raise the arm to about 20 mm above the loading surface of the vice in order to prevent the collision of the saw blade with the vice loading surface. ARG 200 plus, ARG 235 plus and ARG 260 plus E band saws are fitted with a hinged stop that could be set to 90 °. If using the band saw only for perpendicular cuts for a longer time, we recommend that you carry out a precautionary step and swing the band saw into the angle and back at least once a week, because the coolant acts aggressively, which can result in jamming of the arm in one position.

**WARNING!** When using the vertical vice while cutting the workpieces in VP bundles, you can do only perpendicular cuts.

#### 4.5. Saw Blade Guidance

The saw blade is guided by two guide heads both behind and in front of the cut (see the picture in Section 4.8.). The heads are fitted with eccentrically placed bearings and hardened steel blade guides that allow easier rewinding of the saw blade as opposed to wheel guidance. The fixed guide head is attached to a fixed bar. The movable guide head is attached to a movable bar and moves to the distance of 5-10 mm from the movable clamping jaw of the vice. Before the cutting, always check whether the movable guide head and blade cover do not collide with the movable clamping jaw of the vice or with the workpiece within the whole range of arm descent. The guide bars are fitted with protective covers of the saw blade up to the machining area.



**Danger of injury - no cover in the machining area!**

#### 4.6. Arm Back Cover Removal

Switch off the master switch or disconnect the machine from the mains and secure it against restarting. Close the oil damper relief valve (see Section 4.2.) and raise the arm to about 20 mm above the fixed jaw of the vice. Unscrew and slide out the cover of the front rod (A), place it aside and unlock the angled latch (B).

In ARG 200 plus tilt the back cover of the arm (C) (1), lift in the front part (2) and by moving it backwards (3) slide out the back cover. If you want to put the cover back on the machine, use a reversed procedure. In other types ARG 235 - ARG 330 open the back cover (C) upwards and secure with latch or latches (E). Unscrew the blade cover (D) and place it aside. In case of mechanical or electrically powered cleaning sawblade brush, flip sideways.



**Caution: You can remove protective covers only if the MAIN SWITCH is turned off and secured against restart or if the machine is disconnected from the mains.**

**Caution: Danger of injury by the sharp teeth of the saw blade. Use protective gloves. Do not reach between the wheels and the saw blade.**

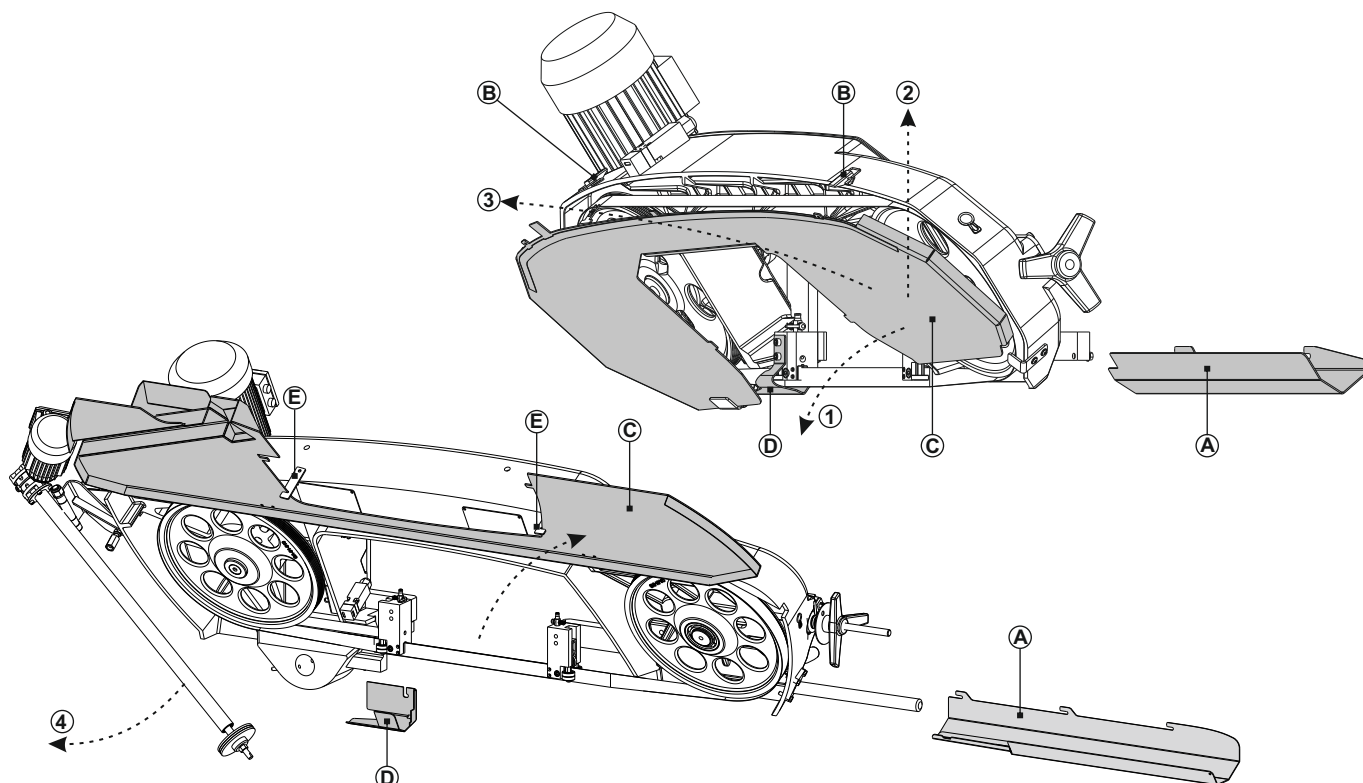

## 4.7. Replacement, Tensioning and Adjustment of the Saw Blade

A timely replacement of the saw blade is needed to achieve good cutting performance, surface finish quality and compliance with workpiece dimensions. Blunt saw blades cause high consumption of electrical power, uneven cuts and rough cutting surfaces. One of the decisive factors affecting the quality of the cut and the life of the cutting tool is a correct and sufficient saw blade tension.



**Caution: You can remove protective covers only if the MAIN SWITCH is turned off and secured against restart or if the machine is disconnected from the mains.**

**Caution: Danger of injury by the sharp teeth of the saw blade. Use protective gloves. Do not reach between the wheels and the saw blade.**

Switch off the MAIN SWITCH or disconnect the machine from the mains and secure it against restarting. Close the oil damper relief valve (see Section 4.2.) and raise the arm to about 20 mm above the fixed jaw of the vice. Remove the protective covers of the saw blade and open/remove the back cover of the arm. Use the tensioning star nut to loosen the tensioning wheel and the whole blade. Take the saw blade off the wheels and push it off the guide heads (see Section 4.8.). Insert the new saw blade in the guide heads. Put it on the wheels and tension the saw blade by a tensioning star nut. **Tension the star nut, so that the disc springs are fully compressed (no light coming through)! In this way, you can achieve correct tensioning of the saw blade.** Install the protective covers of the saw blade and close the back cover of the arm. Turn on the power switch or connect the machine to the mains and switch the machine to the minimum blade speed. Switch on the saw blade START button to let the saw blade run approx. once through and make sure that the saw blade is correctly aligned in the guide heads. Restart the saw blade with the START button and let it turn once. Switch off the MAIN SWITCH or disconnect the machine from the mains and secure it against restarting. Remove the protective covers of the saw blade and open/remove the back cover of the arm, and make sure that the saw blade is correctly fitted on the guide heads and correctly installed on the blade wheels (see figure). If the saw blade is not correctly placed on the wheels, loosen the tensioning star nut and, using the wheel tilt adjusting screw, adjust the position of the saw blade on the wheel (see the picture). **Tension the star nut, so that the disc springs are fully compressed (no light coming through)!** Install the protective covers of the saw blade and close the back cover of the arm. Turn on the MAIN SWITCH or connect the machine to the mains. Carry out a saw blade trial run. Turn off the MAIN SWITCH or disconnect the machine from the mains, remove protective covers of the saw blade and open/remove the back cover of the arm. Check the placement of the saw blade on the wheels. Repeat the procedure, if required. For a quick check of saw blade positioning on the wheels, you can use the BLADE GUIDANCE CONTROL OPENING. Install the protective covers of the blade, close the back cover of the arm and turn on the MAIN SWITCH. Carry out the cutting.

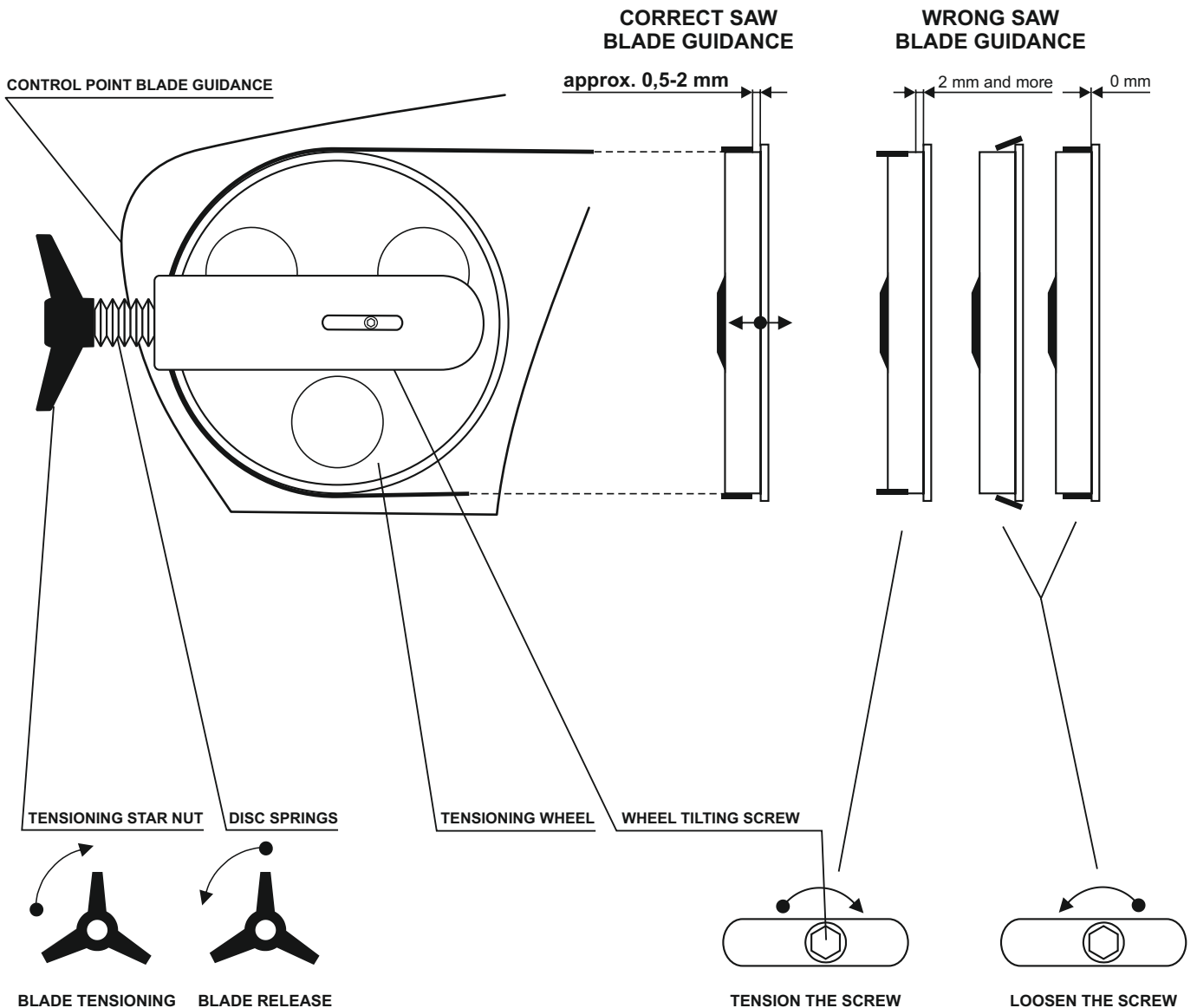

## 4.8. Guide Heads Adjustment

The correct setting of the bearings and the hardened steel blade guides in the guide heads substantially influences the saw blade life and the quality of the cut. The eccentrically arranged guide head bearings must be set in such a manner that the saw blade surface is parallel to the surface of hardened steel blade guides with a minimum play (clearance) between the plates and the blade.

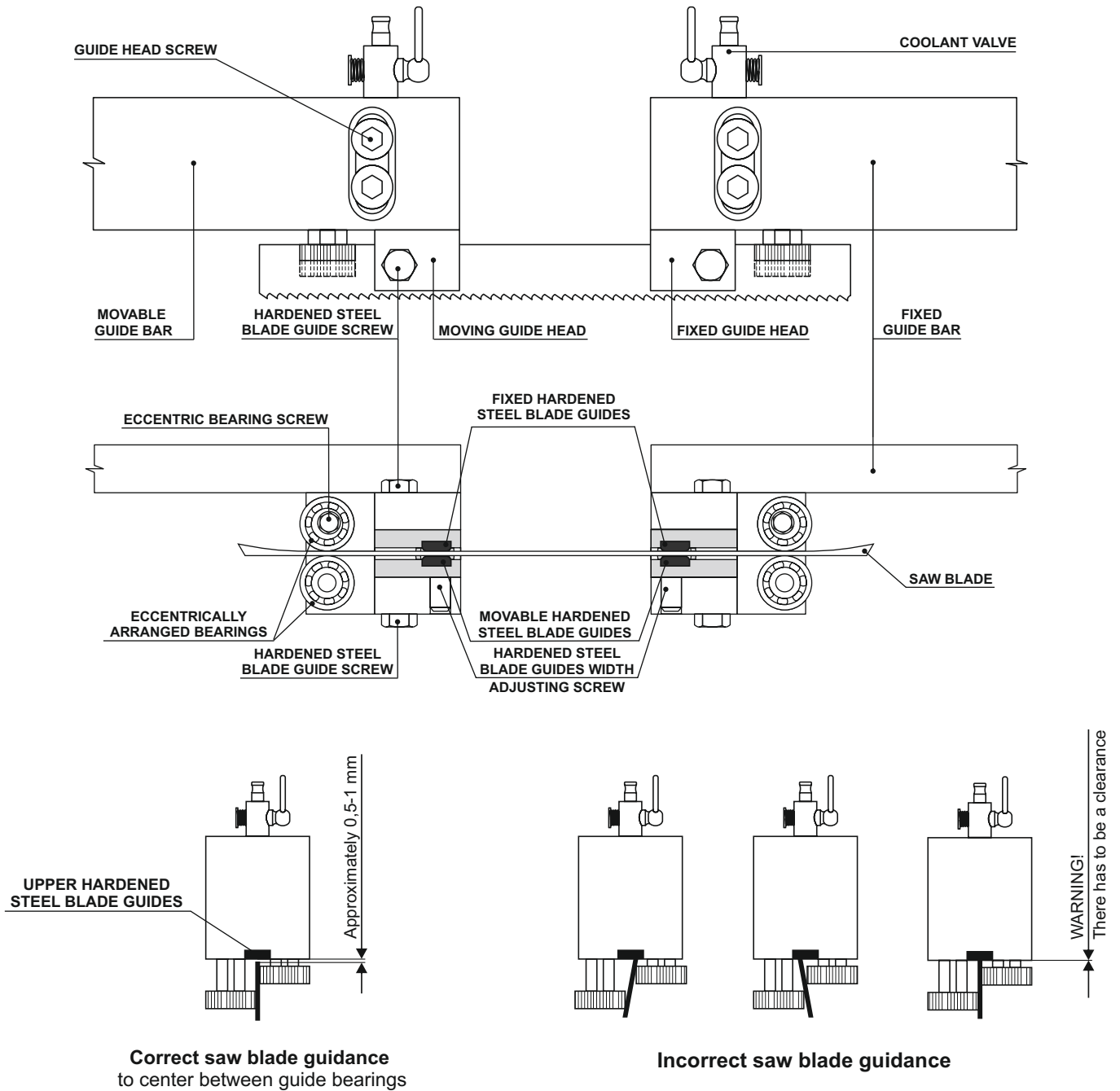

### Guide Head Setting Procedure

Switch off the MAIN SWITCH or disconnect the machine from the mains and secure it against restarting. Close the oil damper relief valve (see Section 4.2.) and raise the arm to about 20 mm above the fixed jaw of the vice. Set the movable guide head, so that the distance between the guide heads is approximately 20 cm. Disconnect the inlet hoses from the coolant valve. Remove the protective covers of the saw blade and open/remove the back cover of the arm. Loosen the tensioning star, take the saw blade off the wheels and push it off the guide heads. Unscrew the guide heads gradually from the fixed and movable bars, turn them by 180° (with bearings and hardened steel blade guides facing upwards) and screw back to the bars. Make sure that the guide heads are perpendicular to the guide bars and that the height of the guide heads is identical. If you find special washers between the guide head and the bar, make sure you place them back afterwards. Check the tightening of the fixed hardened steel blade guides. Insert approximately 30 cm of an old saw blade in the guide heads between the hardened steel blade guides and the bearings. Set the hardened steel blade guides using the width adjusting screw, so that the saw blade does not move between the guides without any play and jamming. When the saw blade has been adjusted, set the eccentrically mounted bearings in such a manner that the bearings do not “cut” the saw blade, but at the same time you have to prevent too much space for the saw blade between the bearings. When the saw blade moves, the bearings are carried along by the saw blade. Make sure that all bolt connections are tight. Unscrew the guide heads from the bars. Fit the saw blade on the wheels, check its correct alignment on the wheels and tension the saw blade. Install both guide heads on the saw blade in the space between the bars and adjust them in the correct position on the bars. Distinguish the correct height setting of the guide heads based on the machine type.

**All types except for ARG 330 F**

You can achieve the correct guide head height in relation to the saw blade by lifting the guide heads, so that the upper hardened steel guide in the guide head is about 0.5-1 mm from the upper edge of the saw blade. See the picture. In this way, the correct guide head height towards the guide bars is achieved.

**ARG 330 F band saw**

You can achieve the correct height of guide head in relation to the saw blade using the screws to set the upper bearing by 0.3-1 mm closer to the saw blade than the hardened steel blade guides. In this case, there will be no clearance between the upper bearing and the blade edge and the bearing will be carried along by the blade.

Set the guide heads perpendicular to the bars and tighten them. If you fail to achieve perpendicularity, the saw blade will either keep sliding off or running into the wheels. Install the protective covers of the saw blade and close the back cover of the arm. Turn on the MAIN SWITCH or connect the machine to the mains. Carry out a saw blade trial run. Switch off the MAIN SWITCH or disconnect the machine from the mains and secure it against restarting. Remove the protective covers of the saw blade and open/remove the back cover of the arm. Check the placement of the saw blade on the wheels and in guide heads. Make a correction, if necessary - see section 4.7.. Install the protective covers of the blade, close the back cover of the arm and turn on the MAIN SWITCH or connect the machine to the mains. Carry out the cutting. You can watch the video with instructions on [www.pilous.cz](http://www.pilous.cz).

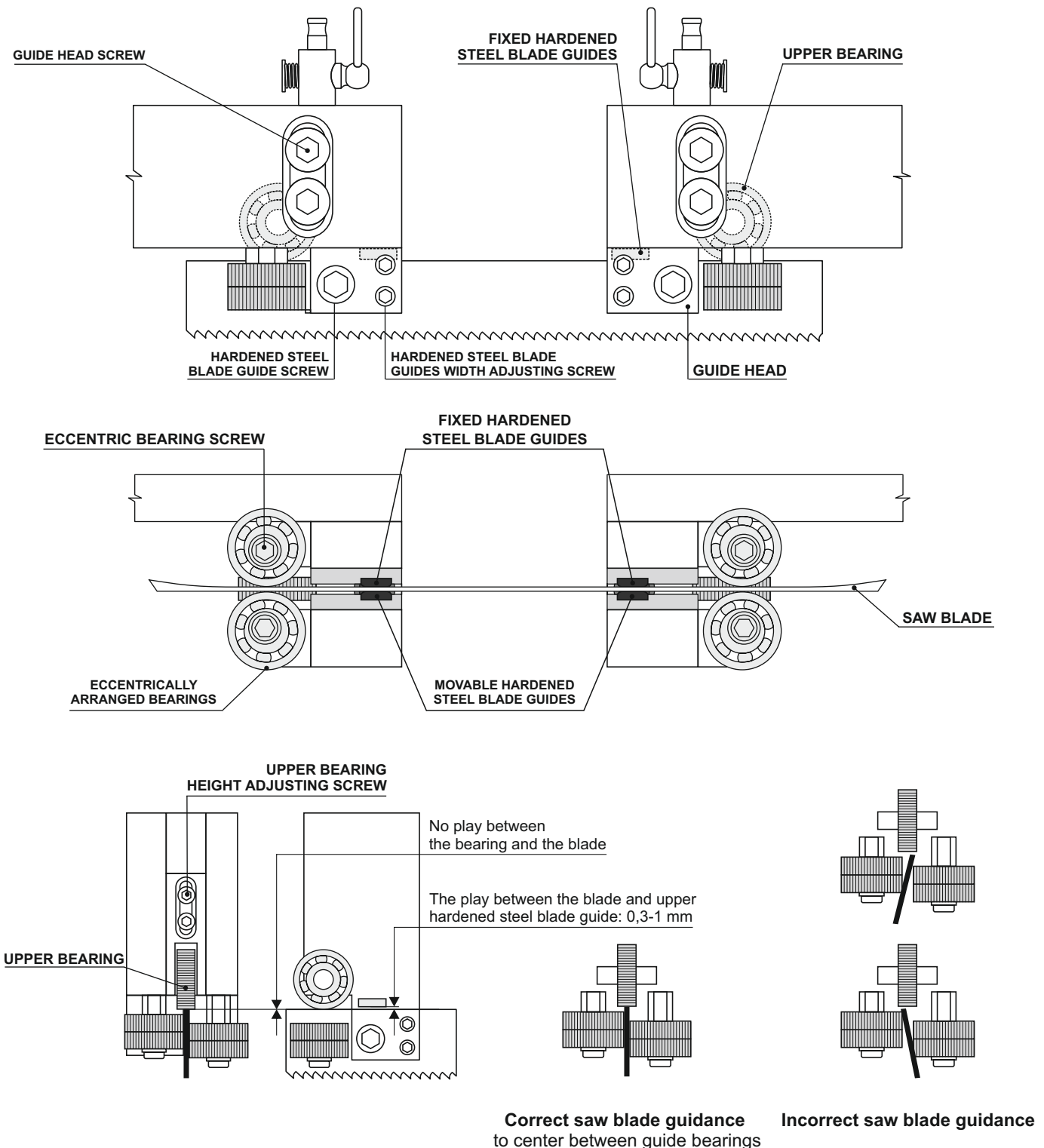

## 4.9. Cooling System

The pump and the coolant tank, which are mounted in the machine base, are the basic elements of the cooling system. You can remove the coolant tank without the pump. The coolant pump conveys the coolant via hoses, valves and guide heads to the saw blade. The volume of the coolant is regulated by the valves on the guide heads. The coolant cools down and lubricates the saw blade and flushes away metal chips. The pump switches on and off when the saw blade drive is started or shut down. There is a setting container in the the coolant tank, which needs to be cleaned during regular checks depending on the material to be cut. It is important that the pump is always immersed in the coolant that facilitates its cooling. **If the level of the coolant gets too low during cutting, the pump will be irreparably damaged.**



There is an overflow opening in the coolant tank, ensuring the right volume of the coolant in order to prevent flooding of the pump (danger of burning the pump). **If you fill in too much coolant, it may leak under the saw.**



When handling coolants, risks linked to hazardous substances cannot be avoided. Observe the manufacturer's and/or your company's instructions and recommendations referring to safe coolant handling.

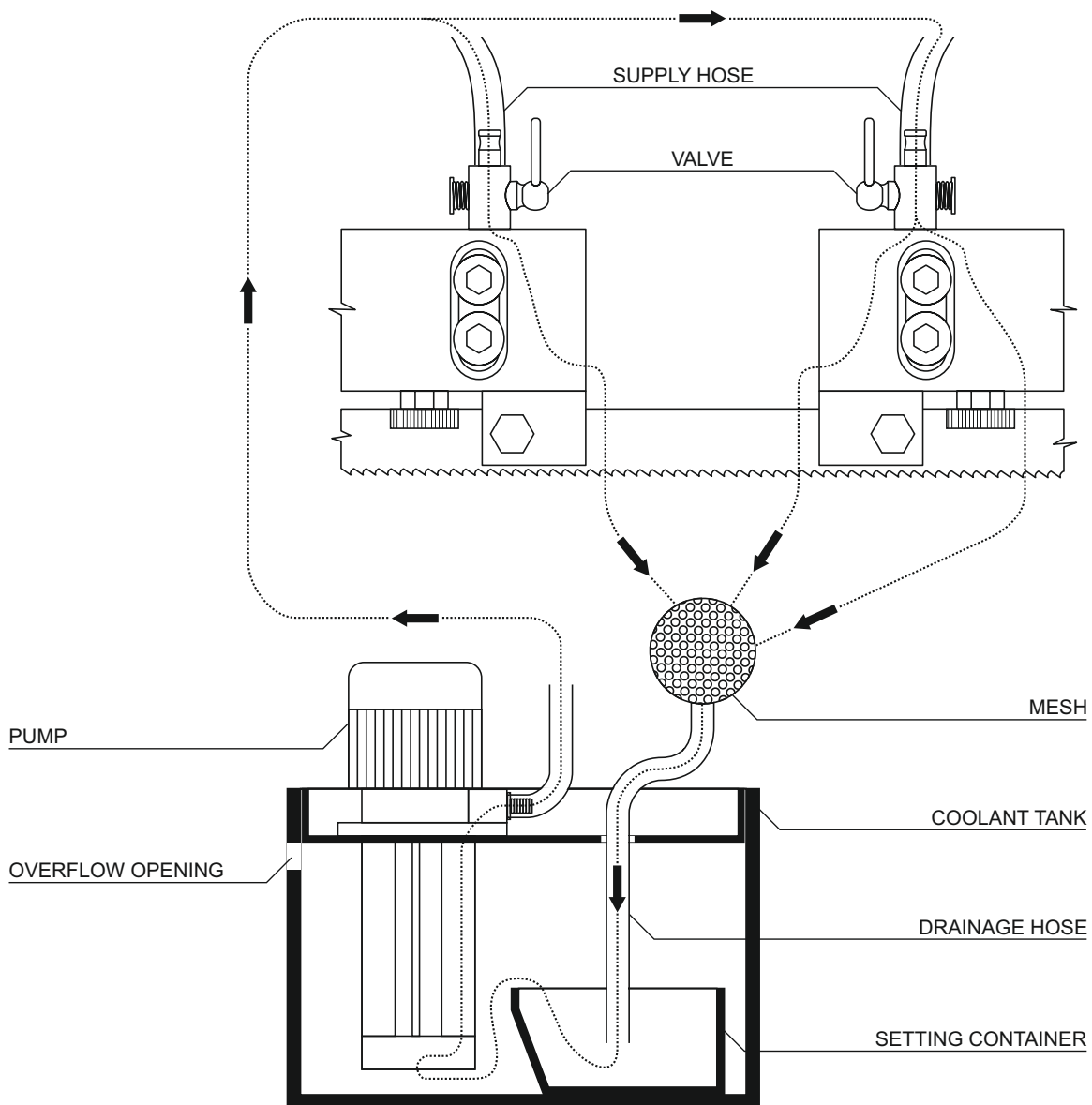

## 5. Commissioning

### 5.1. Security Check



Is everything in perfect condition with regard to safety and technical condition?  
Are all protective devices mounted properly?

### 5.2. Cutting Procedure



**Danger of injury!**  
**No cover on the saw blade in the cutting area!**  
**High risk of injury in the operating area of the blade!**

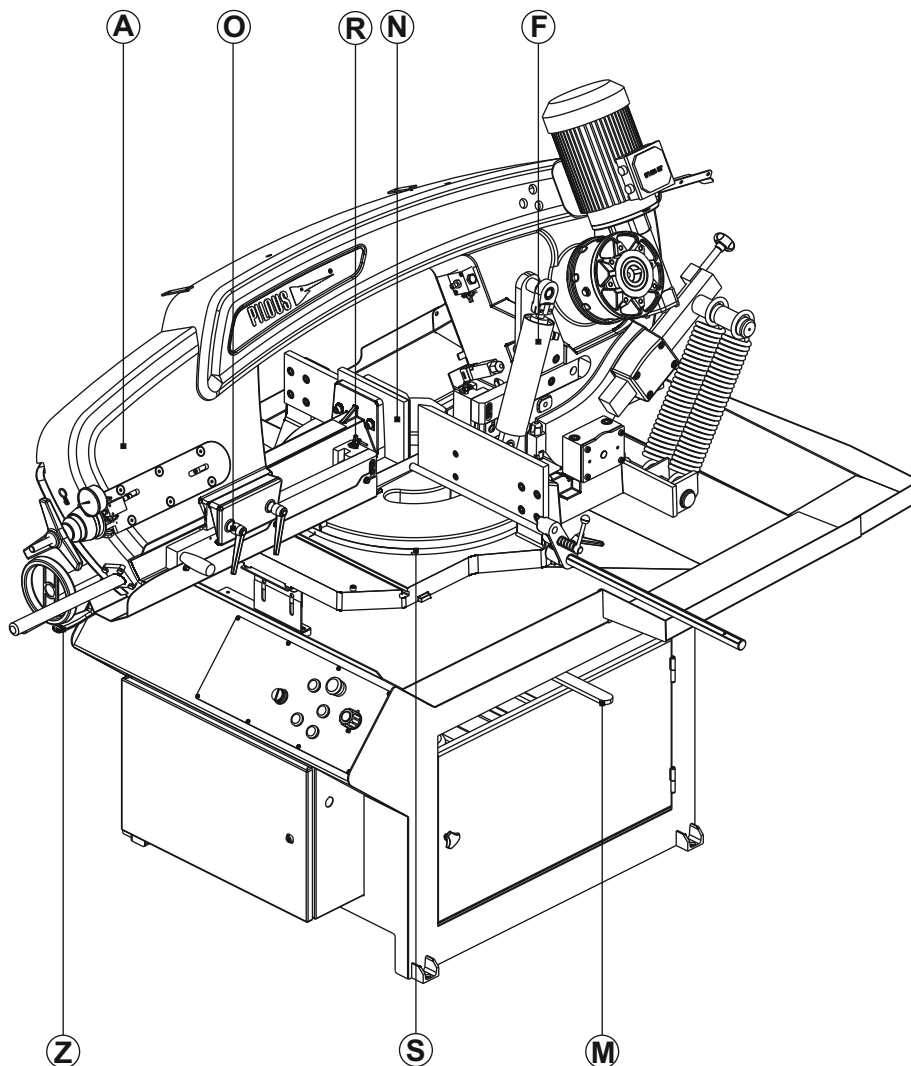

The TOTAL STOP button is unlocked. Unlock the arm swing locking lever (M), raise the saw arm (A) to the limit upper position and by swinging the arm, set the required cutting angle on the angle scale (S), and lock the arm swing locking lever (M) again. Open the moving clamping jaw (N) to such extent that allows for unhindered insertion of the workpiece between the jaws. Push the workpiece. You cannot align long heavy workpieces to the correct position by the moving clamping jaw. After the feed, the material must be aligned. Asymmetric or thin-walled sections have to be stabilized and fixed in place using fittings made e.g. of hardwood etc. Choose the length of the cut workpiece. Move the moving clamping jaw (N) closer to the workpiece and clamp it by the quick-clamping lever (Z). Carefully lower the arm (saw blade)(A) to approximately 20-30 mm above the planned cross-section of the workpiece and secure by closing the oil damper relief valve (F). Set the correct distance of the movable guide head of the saw blade (R) to approximately 5 - 10 mm from the movable clamping jaw of the vice (N) and lock using the moving bar locking lever (O). Choose the cutting speed. Switch on the saw blade motor. Set the speed of arm descent to the cut using the relief valve. The optimum value of descent can be determined very easily by ear. The saw blade movement must be noiseless, free from vibrations. Such a state can be achieved by reducing or increasing the pressure force (by the velocity of saw arm descent). The prerequisite of setting the optimum pressure is selecting the correct saw blade velocity and the optimum size of the saw blade teeth, see Section 8. Saw blades. After cutting the workpiece, the saw blade automatically switches off.

The cut has been finished. Saw arm - the saw blade is located in the lower limit position. The saw blade stopped and the motor is turned off. You can watch the video with instructions on [www.pilous.cz](http://www.pilous.cz).

## 6. Machine Maintenance

### 6.1. Maintenance and Inspection



#### **Danger of injury!**

**Carry out the maintenance work only if the power switch is off or if the machine is disconnected from the mains.**

Care and maintenance is absolutely necessary to maintain the functionality of the machine and its components. This includes: check and adjustment of band saw guide heads and limit angles cleaning metal chips removal removing metal chips from the internal part of the band saw arm coolant exchange lubrication of sliding surfaces and mounting checking of supply lines for damage vice check screw connection checking limit switch checking.



#### **Check protective devices**

Check the protection devices for possible damages and faults prior to the start of everyday work.



#### **Check power cable**

Check in regular intervals, at least once a week: integrity of electric installation integrity of connections and relief from pulling



#### **Cleaning**

Clean the machine in regular intervals (always at the end of the shift, or if required, during the shift). Use suitable cleaning agents. Do not use solvents (e.g. nitro thinner). Do not use compressed air! Compressed air would blow delicate chips and dirt particles under sliding elements or endanger the health of personnel by flying particles.

#### **Removal / disposal of chips**



**Observe the instructions and recommendations concerning safe disposal of waste produced during operation.**

Correct cutting angles will be achieved when the bearing surfaces for the workpiece and the surfaces of gripping jaws are free from metal chips or other impurities.

#### **Coolant system cleaning**



**When handling coolants, risks linked to hazardous substances cannot be avoided. Observe the regulations and recommendations (operating instructions by professional associations or your company) related to safe handling of coolants.**

The coolant tank cannot be removed from the machine base during the maintenance and cleaning. The coolant is limited by the length of the power cable and coolant hose. **Caution: Used coolant belongs to special waste category!**

**Our recommendations:** Regular cleaning and maintenance of the coolant increases the service life and functionality of the coolant pump. If possible, use the coolants miscible with water, non-irritant to skin and with high protection against aging and corrosion. At least once a week, check the quality of the coolant according the coolant manufacturer's recommendations. Optimum lubrication increases cutting productivity. There is a setting container in the the coolant tank, which needs to be cleaned during regular checks depending on the material to be cut.

#### **Lubrication**

Regular lubrication and cleaning extend the life and functionality of the machine. During the periodic inspection, check whether there is enough lubricant on the friction surfaces and trapezoidal screw of the vice (see the picture) and in friction surfaces on the movable bar of the saw blade. Or you can lubricate these areas with grease, such as MOGUL LV 2 WR (classified in accordance with: ISO 6743 - BCHB 2, DIN 51 502 - KP2K-20).

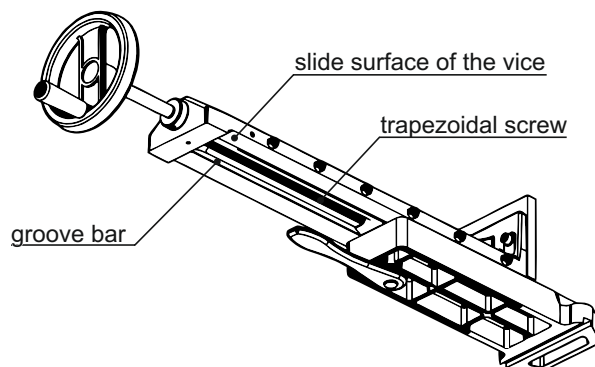



### 6.2. Repairs



#### **Caution: Danger of injury!**

**Carry out repairs only when the master switch is off or secured against switching on or when the machine is isolated from the power supply and secured against restarting. We recommend that you contact an authorised service centre for repairs.**

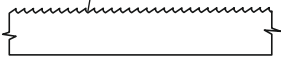
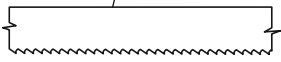
## 7. Failures - Potential Causes and Remedies

Failure	Possible cause	Remedy
Saw blade feed cannot start	<ul style="list-style-type: none"> <li>The power switch is off</li> <li>The TOTAL STOP button is locked.</li> <li>The protective overcurrent relay is off</li> <li>The end switch of the arm cover not actuated</li> <li>The control board fuse is burnt</li> <li>The saw arm is in the lowest position, the limit switch is pressed</li> </ul>	<ul style="list-style-type: none"> <li>Turn on the power switch</li> <li>Unlock the TOTAL STOP button</li> <li>Check motor protective switch</li> <li>Check the arm cover</li> <li>Replace the fuse</li> <li>The saw arm must be raised when the saw blade starts</li> </ul>
The motor is on, but the saw blade is not moving	<ul style="list-style-type: none"> <li>The saw blade slips on the blade wheel</li> <li>Broken blade</li> <li>Other fault in the gearbox</li> </ul>	<ul style="list-style-type: none"> <li>Tension the blade properly (see section 4.7.)</li> <li>Replace it (see section 4.7.)</li> <li>Call the service technician</li> </ul>
Irregular cooling	<ul style="list-style-type: none"> <li>Coolant used up</li> <li>The coolant tank and/or supply pipes or the ball valves are contaminated</li> <li>Broken pump</li> </ul>	<ul style="list-style-type: none"> <li>Check the coolant</li> <li>Clean the coolant tank and supply pipes</li> <li>Replace the pump</li> </ul>
Vibration during cutting	<ul style="list-style-type: none"> <li>The feed to the cut occurs within a non-desirable range</li> <li>Wrong selection of saw blade tooth size</li> <li>Incorrectly adjusted guide heads, hardened steel blade guides, bearings</li> <li>Incorrectly clamped material</li> </ul>	<ul style="list-style-type: none"> <li>Set 5% less/more feed to the cut</li> <li>Check the tooth size</li> <li>Adjust it, see section 4.8.</li> <li>Check workpiece clamping</li> </ul>
Broken teeth stuck in the cutting channel in the workpiece		<ul style="list-style-type: none"> <li>Do not cut into an old cutting channel with a new blade! Otherwise you damage the new blade with the first cut</li> </ul>
The cut is not rectangular	<ul style="list-style-type: none"> <li>Incorrectly set cutting angle</li> </ul>	<ul style="list-style-type: none"> <li>See Section 4.4.2.</li> </ul>
The blade cuts under	<ul style="list-style-type: none"> <li>Blunt saw blade</li> <li>Wrong selection of saw blade tooth size</li> <li>Feed to the cut is too quick</li> <li>The blade slid under guide bearings</li> <li>Clearance between hardened steel blade guides</li> <li>The workpiece is not placed parallel with the vice loading surface</li> </ul>	<ul style="list-style-type: none"> <li>Replace the blade</li> <li>Check the tooth size, see section 8.2.</li> <li>Adjust the feed</li> <li>Insert the blade properly (see section 4.7.)</li> <li>Adjust it, see section 4.8.</li> <li>Align the roller conveyor, check workpiece clamping</li> </ul>
Saw blade cracking between teeth 	<ul style="list-style-type: none"> <li>Wrong selection of saw blade tooth size</li> <li>Feed to the cut is too quick</li> <li>Incorrectly adjusted or damaged guidance through heads (hardened steel blade guides, bearings)</li> <li>The moving guide head is too far from the workpiece</li> <li>Insufficient cooling</li> </ul>	<ul style="list-style-type: none"> <li>Check the tooth size, see section 8.2.</li> <li>Adjust the feed</li> <li>Adjust (see section 4.8.) or replace them</li> <li>Move it closer, see section 4.5.</li> <li>Increase the coolant supply</li> </ul>
Saw blade cracking on the face 	<ul style="list-style-type: none"> <li>Incorrectly clamped workpiece while cutting a bundle</li> <li>Saw blade incorrectly placed on wheels (runs into the fitting)</li> <li>Wrong selection of saw blade tooth size</li> <li>Feed to the cut is too quick</li> <li>Incorrectly adjusted or damaged guidance through heads (hardened steel blade guides, bearings)</li> <li>The moving guide head is too far from the workpiece</li> </ul>	<ul style="list-style-type: none"> <li>Clamp the workpiece properly</li> <li>Check, see section 4.7.</li> <li>Check the tooth size, see section 8.2.</li> <li>Adjust the feed</li> <li>Adjust (see section 4.8.) or replace them</li> <li>Move it closer, see section 4.5.</li> </ul>
The feed to the cut is not constant, sinks	<ul style="list-style-type: none"> <li>Not enough oil in the oil damper system</li> </ul>	<ul style="list-style-type: none"> <li>Call the authorised service centre</li> </ul>
The arm descends even when the relief valve is closed	<ul style="list-style-type: none"> <li>Loosened M4 screw on control valve's wheel - turns loosely</li> <li>Valve seat is worn out</li> <li>Cylinder sealing is worn out</li> <li>Valve failure (impurities)</li> </ul>	<ul style="list-style-type: none"> <li>Tighten it</li> <li>Tighten M4 lock screw, turn wheel approx. 10° to the left and tighten</li> <li>Call the authorised service centre</li> <li>Call the authorised service centre</li> </ul>
Red light on the control panel indicating a frequency converter error	<ul style="list-style-type: none"> <li>The protective function for frequency converter overload has responded</li> </ul>	<ul style="list-style-type: none"> <li>Press STOP button on the frequency converter RESET </li> </ul>

The adjustment of guide heads is a matter of regular maintenance and that is why such fault is not covered by the guarantee.



## 8. Saw Blades

### 8.1. Saw Blade Design

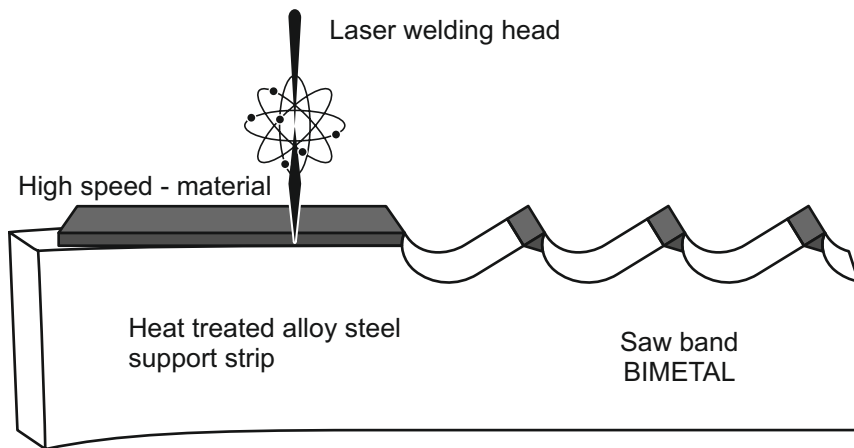

The prerequisite of the correct cutting power of the machine is the use of high-quality saw blades. In order to achieve a high cutting power, it is recommended to use bimetallic saw blades. The main saw blade component is a high-quality heat treated steel with a high elasticity limit. The tooth edges are high-speed steel of the following quality: M 42, M 51.

**M 42** - a saw blade for universal use for cutting metallic and non-ferrous materials within the whole range of quality classes up to the 45 HRC hardness. The saw blade is suitable for cutting full materials of all cross-sections and diameters, profiles, pipes and bundles.

**M 51** - with reference to the M 42 saw blade, the M51 is designed first of all for cutting steel up to 50 HRC, steel of higher strength classes, acid-resistant and stainless steels. Furthermore, for cutting nickel, titan alloys and special grade of bronze.

**Carbide** - high cutting power as compared to bimetallic saw blades. Suitable for cutting of steel, non-ferrous metals, material with high content of chrome, nickel, titan, stainless steel and face-hardened materials up to 62 HRC. The saw blades can be used for all materials including stainless steel, tool steel, non-ferrous metals, cast iron, plastics and fibreboards. Characteristics of these saw blades include a high thermal conductivity, high wear and tear resistance and thus longer life, higher cutting speed, less frequent saw blade replacements and better productivity as compared with carbon steel saw blades.

Design: M 42 - composition: W 2%, Mo 10%, V 1%, CO 8%, tooth hardness: 68 HRC. For cutting of materials up to 45 HRC  
 Design: M 51 - composition: W 10%, Mo 4%, V 3%, Co 10%, tooth hardness: 69 HRC. For cutting of materials up to 50 HRC  
 Design: Carbide - tooth hardness 1600 HV. For cutting of materials up to 62 HRC.

In addition to standard shapes and sizes of teeth, the saw blades are also manufactured with special features, such as saw setting, tooth angle and tooth face shape, which are used particularly for cutting of specific materials. Please contact your saw blade supplier to get more information about these features.

#### Saw Blade Tooth Arrangement

- a) **Constant** - tooth edge spacing always equal
- b) **Variable** - the tooth edge space is different, repeating periodically. This modern saw blade design enables a bigger cutting range in one saw blade type. It is able to eliminate vibrations caused by the tooth edge touching the material and thus to achieve a clean smooth cut and longer service life.

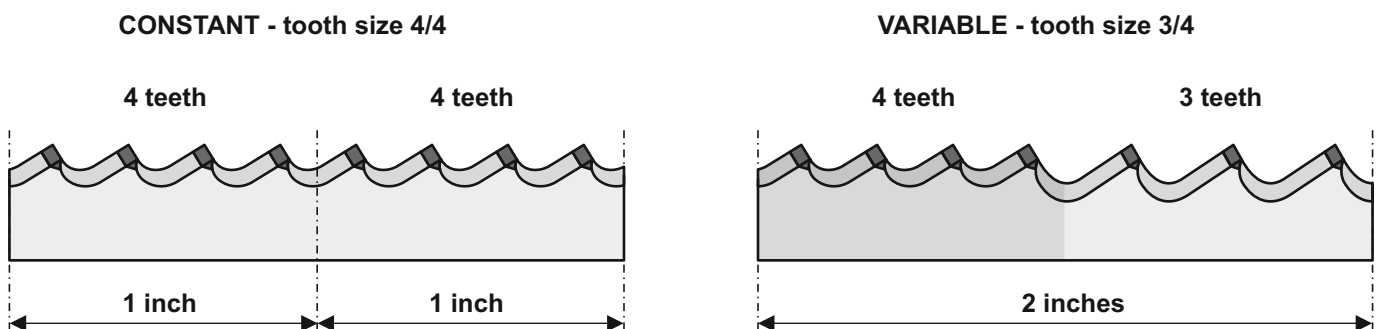

## 8.2. Selection of Tooth Size

The selection of the tooth size is of crucial importance for the saw blade service life.

### Tooth sizes recommended for cutting full materials

		ARG 200 saw blade 20x0,9		ARG 235, 260, 300 saw blade 27x0,9			ARG 330 saw blade 34x1,1		
Material cross-section	Number of teeth per inch	Tooth quality M42/67-69 Hrc	Carbide 1600 Hr	Tooth quality M42/67-69 Hrc	Tooth quality M51/69 Hrc	Carbide 1600 Hr	Tooth quality M42/67-69 Hrc	Tooth quality M51/69 Hrc	Carbide 1600 Hr
0-10	14z	●		●			●		
0-25	10/14	●		●			●		
20-40	8/12	●		●			●		
20-40	8/11	●		●					
30-60	6/10	●		●			●		
40-70	5/8	●		●			●		
40-70	5/7	●		●	●		●		
60-110	4/6	●		●	●		●	●	
80-120	4z	●		●		●			
90-140	3/4	●		●	●	●	●	●	●
120-200	3z	●	●	●		●			
120-350	2/3z			●	●	●	●	●	●
200-400	2z			●					
250-550	1,4/2						●		●

The following table refers to piece-by-piece cutting of sectional materials. If the material is cut in bundles, the forces of the walls of individual tubes must be added with regard to their diameters.

### Tooth sizes recommended for cutting sections

Wall width mm	External tube diameter D (mm)													
	20	40	60	80	100	120	150	200	300	400	500	600	700	
2	14	14	14	14	14	14	10/14	10/14	8/11,8/12	8/11,8/12	6/10	6/10	5/7,5/8	
3	14	14	14	10/14	10/14	10/14	8/11,8/12	8/11,8/12	6/10	6/10	5/7,5/8	5/7,5/8	5/7,5/8	
4	14	14	10/14	10/14	8/11,8/12	8/11,8/12	6/10	6/10	5/7,5/8	5/7,5/8	5/7,5/8	4/6	4/6	
5	14	10/14	10/14	8/11,8/12	8/11,8/12	6/10	6/10	5/7,5/8	5/7,5/8	4/6	4/6	4/6	4/6	
6	14	10/14	8/11,8/12	8/11,8/12	6/10	6/10	5/7,5/8	5/7,5/8	4/6	4/6	4/6	4/6	3/4	
8	14	8/11,8/12	6/10	6/10	5/7,5/8	5/7,5/8	5/7,5/8	4/6	4/6	4/6	4/6	3/4	3/4	
10		6/10	6/10	5/7,5/8	5/7,5/8	5/7,5/8	4/6	4/6	4/6	3/4	3/4	3/4	2/3	
12		6/10	5/7,5/8	5/7,5/8	4/6	4/6	4/6	4/6	3/4	3/4	3/4	2/3	2/3	
15				4/6	4/6	4/6	4/6	4/6	3/4	3/4	2/3	2/3	2/3	
20				4/6	4/6	4/6	4/6	3/4	3/4	2/3	2/3	2/3	2/3	
30				4/6	4/6	4/6	3/4	3/4	2/3	2/3	2/3	2/3	2/3	
50						3/4	3/4	2/3	2/3	2/3	2/3	1,4/2	1,4/2	
75								2/3	2/3	2/3	1,4/2	1,4/2	1,4/2	
100									2/3	2/3	1,4/2	1,4/2	1,4/2	
150									1,4/2	1,4/2	0,75/1,25	0,75/1,25	0,75/1,25	
200											0,75/1,25	0,75/1,25	0,75/1,25	
250											0,75/1,25	0,75/1,25	0,75/1,25	
300												0,75/1,25	0,75/1,25	

**Caution:** The aforementioned values do not apply to cutting of different sectional materials. Such a requirement must be treated with respect to the shape of the sectional material, the number of pieces in the bundle and the dimensions. When the saw blade is used for cutting sectional materials, its service life will decrease by up to one third due to interrupted cutting.

**Rule:** At least four, but not more than thirty teeth must cut in while a workpiece is being cut.

### 8.3. Optimum workpiece clamping

Correct workpiece clamping can significantly influence the service life of the saw blade and the cutting accuracy. Moreover, it allows for correct selection of tooth size. To cut material in bundles, we recommend to use upper (vertical) pressure device. In order to achieve the optimum cut (service life and cutting performance), observe these ways of clamping.

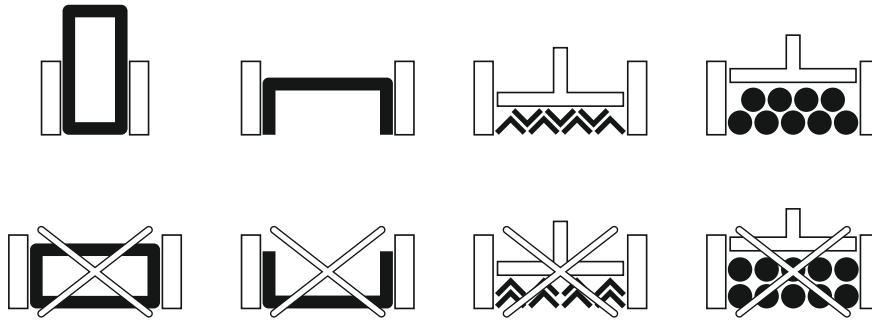

### 8.4. Running-in New Saw Blades

The running-in applies to new saw blades. The sharp cutting edges with extremely small edge radii enable high cutting power. In order to achieve maximum tool service life, you have to run in (optimum) the new saw blade. Given the correct cutting speed, the workpiece feed and the quality of its material, the saw blade must be run in only with 50% of currently used feed. Such measure will help you prevent breaking extremely sharp edges particularly in big workpiece sections. These micro-fragments cause destruction of other teeth. Should vibrations or noise due to oscillations manifest themselves when a new saw blade has been fitted, reduce the cutting speed slightly. In small workpiece sections it is recommended to run in the saw blade with a reduced power for 15 minutes, in big sections for 30 minutes. Then increase the feed slowly to the optimum value.

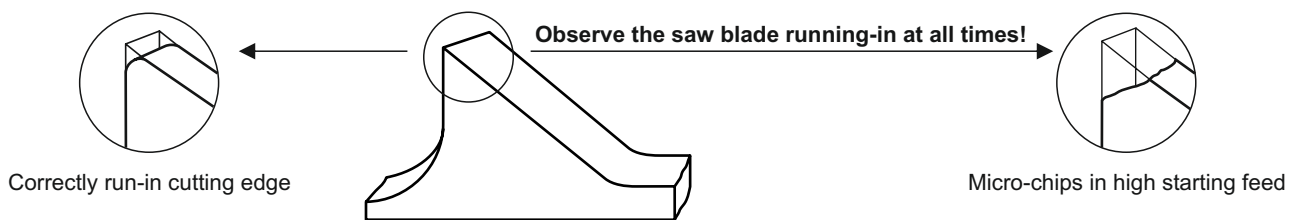

### 8.5. Factors Influencing Saw Blade Service Life

Inappropriate saw blade tooth size • inappropriate saw blade speed and saw blade descent speed to the cutting position • the saw blade (the whole band saw arm) leans against the workpiece when the band saw is not in the cutting position • the workpiece is not clamped as recommended • saw blade tension is not correct (mostly too little tension) • the saw blade is not correctly fitted on the guide wheels (the saw blade touches the wheel shoulder) • the saw blade guide heads are not correctly adjusted • the distance between the saw blade guide heads and the workpiece is too big • the oil content of the coolant is too low • the saw blade is not correctly run in • saw blade maintenance is insufficient, metal chips have not been removed from the band saw.





**The above mentioned faults lead to inaccurate cut, reduction of the saw blade service life and/or its destruction.**

### 8.6. Values Recommended for Cutting

The selection of values depends on the material class and the material section. The data in the table are only illustrative; they have to be adjusted to the material for certain ranges. The numbers of the CSN-Standards serve for information only. They define only the guide for the material properties for which the respective saw blade type is designed.

Material		Recommended blade speed (m/min)		Arm descent speed into the cut (mm/min)		Cooling oil volume (%)
ČSN	In general	ø 0-100 mm	ø 100-330 mm	ø 0-100 mm	ø 100-330 mm	
11 107 - 11 110	Free-cutting steel	70-90	70-90	190-60	55-20	10-15
11 301 - 11 420 / 12 010 - 12 020	Structure/construction steel	60-90	60-80	190-60	55-30	10-15
11 500 - 11 600 / 12 020 - 12 060	Cementing steel	60-90	50-70	125-38	35-25	10-15
13 250 / 14 260 / 15 260	Spring steel	50-70	40-60	125-30	28-15	5-10
14 100 / 15 220	Bearing steel	50-70	30-60	125-30	28-15	3
14 220 / 15 124	Alloy steel	50-80	40-70	125-35	30-20	10
17 020 - 17 042	NIRO steel	40-50	30-40	75-15	12-4	10-15
17 115	Valve steel	40-60	30-50	90-23	21-10	3
17 253 - 17 255	Heat-resistant steel	30-40	30	40-7	6-1	15
19 063 - 19 083 / 15 142 / 16 142	Refining steel	60-90	40-70	125-35	30-25	5-10
19 150 / 19 192 - 19 312	Non-alloy tool steel	50-70	30-60	120-25	20-8	5-10
19 422 / 19 452 / 19 721 / 19 740	Alloy steel	40-50	30-50	100-20	18-2	5-10
19 436	Hammer steel	30-40	30-40	62-15	14-5	do not
19 662	Nitriding steel	40-50	30-40	76-25	23-12	5
19 721	Tool steel for hot processing	30-40	30	70-1	16-6	5
19 802 - 19 860	High speed steel	40-60	30-50	90-23	21-10	3
INCONEL, HASELLOY, NIMONIC, INCOLOY		30	30	25-5	4-2	15-20
Heat-treated steel		30	30	25-5	4-2	15-20
Cast steel		30-70	30-60	190-60	55-25	40
Grey cast iron		40-80	30-70	190-60	55-30	do not
Copper, bronze, tin bronze		70-90	60-90	300-90	85-55	3
Red bronze		70-90	60-90	230-75	70-45	10
Aluminium bronze		40-70	30-60	230-75	70-45	10-15
Aluminium alloy castings		80-90	80-90	450-150	140-55	25
Al 99%, thermoplastics, plastics		50-90	50-80	450-150	140-55	do not

## 9. Nameplate

				
MANUFACTURER	Producer Pilous-pásové pily, spol. s r.o. Address Železná 9, 619 00 Brno, CZ			
MANUFACTURER'S ADDRESS				
MACHINE MODEL	Model	ARG 235 Plus	Year	2018
SERIAL NUMBER	Serial No.	22/08/0062		285kg
TOTAL WATTAGE	P	1.6kW	I	3.5A
OPERATING VOLTAGE	U	3x400V/50Hz		400/24
			YEAR OF MANUFACTURE	
			MACHINE WEIGHT	
			RATED CURRENT	
			CONTROL VOLTAGE	

The data are only illustrative

## 10. Wiring diagram

### 10.1. ARG 200 plus, ARG 235, ARG 235 plus, ARG 260 plus E, ARG 260, ARG 260 plus wiring diagram

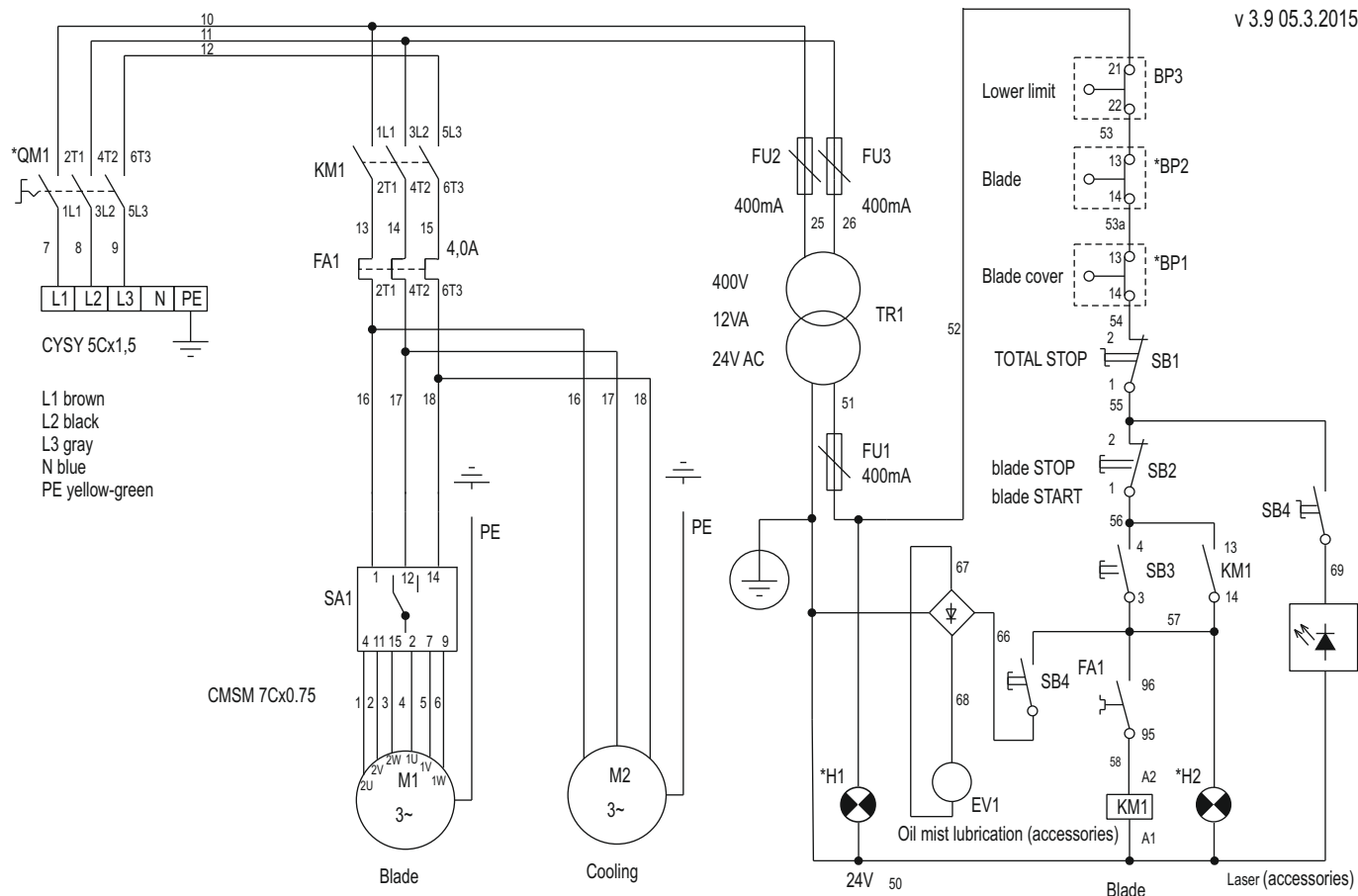

\* component fittings may vary with the type of the saw

v3.9 10.1.2013

Diagram:	Name:	Type:	Order No:
Qm1	Switch	OT 16 FT3	017074
	OT switch - accessories	OTS 32 T 3	002863
	OT switch - accessories	OHBS2PJ	017076
SA1	Motor M1 speed switch	ON8XBS16616	009655
BP1	Blade cover end switch	FW 3392-M1 D1	014948
	Blade cover end switch	PZ FR 693 - D1-M16	002532
BP2	Blade tensioning end switch	FR 615	002491
BP3	Lower position limit switch	FR 6A1	002490
KM1	Contactor	Contactor DILEM - 10/24/50 24V/50-60Hz 10A	011829
FA1	Thermal relay	Thermal relay ZE - 4.0	011833
SB1	TOTAL STOP button	YW1B-V4E01R	006104
SB2	MO head pressing red	M22-D-R	006086
	MO head connection	M22-A	006103
	Mo switch, unit 1off	M22-K01	006091
SB3	MO head grip.green-lit	M22-DL-G	006098
	MO head grip.green-lit	M22-D-G	006087
	MO head connection	M22-A	006103
	MO switch, unit 1on	M22-K10	006090
H2	MO led socket green	M22-LED-G	006094
	MO head sig. white	M22-L-W	006095
	MO head connection	M22-A	006103
H1	MO led socket white	M22-LED-W	006092
	MO head connection	M22-A	006103
Tr1	Isolation transformer	400/24V 12VA	001899

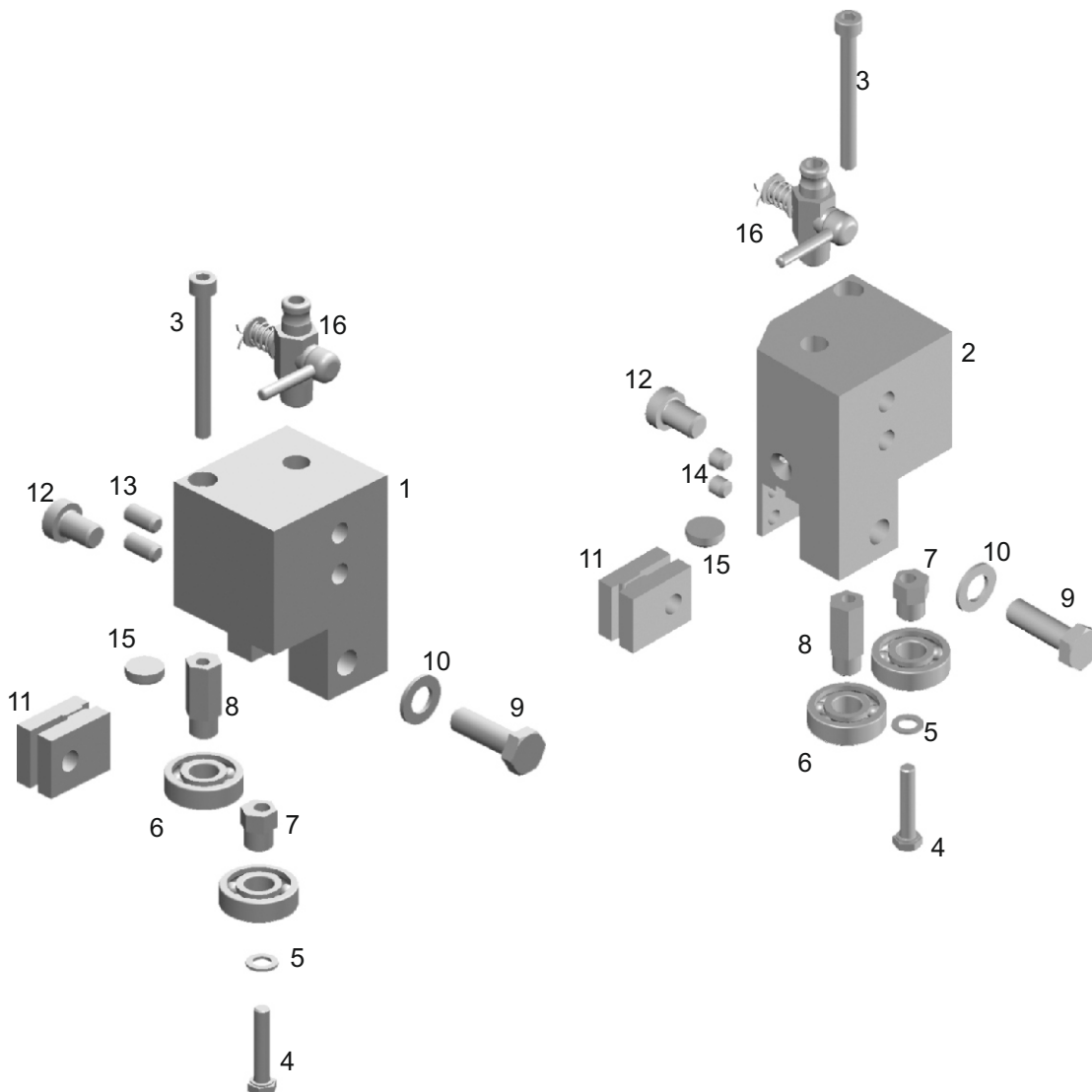

Diagram:	Name:	Type:	Order No:
Bp1	Blade cover end switch	FW 3392-M1 D1	014948
		Safety switch key	014950
	Blade cover end switch	PZ FR 693 - D1-M16	002532
BP2	Blade tensioning end switch	FR 615	002491
	Blade tensioning end switch	PZ-NFB110BB-DN7	020687
BP3	Lower position limit switch	FR 6A1	002490
KM1	Contactator	DILEM - 10/24/50 24V/50-60Hz 10A	011829
KM2	Contactator	DILEM - 10/24/50 24V/50-60Hz 10A	011829
	Aux. contact	F-MO 22	011837
FQ1	Circuit breaker	S 203-C10	003896
FQ2	Trigger	MS325+HKF11/0.4-0.63A	002702
FU1	The fuse holder	Fuse terminal 5x20 tiltable	001779
	Fuse glass	2A	001597
FU2	The fuse holder	Fuse terminal 5x20 tiltable	001779
	Fuse glass	2A	001597
FU3	The fuse holder	Fuse terminal 5x20 tiltable	001779
	Fuse glass	400mA	001971
TR1	Isolation transformer	400/24V 40VA	014107
SB1	MO head lock Red	YW1B-V4E01R	006104
H1	MO head sig. white	M22-L-W	006095
	MO head connection	M22-A	006103
	MO led socket white	M22-LED-W	006092
SB2	MO head pressing Red	M22-D-R	006086
	MO head grip.red-lit	M22-DL-R	017172
	MO head connection	M22-A	006103
	MO switch, unit 1on	M22-K10	006090
	Mo switch, unit 1off	M22-K01	006091
H3	MO led socket red	M22-LED-R	006093
SB3	MO head grip.green-lit	M22-DL-G	006098
	MO head connection	M22-A	006103
	MO switch, unit 1on	M22-K10	006090
H2	MO led socket green	M22-LED-G	006094
PF1	1.5kW frequency converter	ATV312HU15N4	020978
	2.2kW frequency converter	ATV312HU22N4	021015
	3.7kW frequency converter	ATV312HU40N4	021016
P1	Potentiometer	TP195 4K7/N	002780
	Machine button	pr. 34.8mm	002781
Qm1	Switch	OT 16 FT3	017074
	OT switch - accessories	OTS 32 T 3	002863
	OT switch - accessories	OHBS2PJ	017076

# 11. Assemblies

## 11.1. Guide Head Assembly

### 11.1.1. Guide Head Assembly in ARG 200 - 300



ver. 1.1.2016

Pos	Order number	Name	Type ARG	Pcs	Pos	Order number	Name	Type ARG	Pcs
1	022964	Guide head moving	200	1	8	022966	Exc. bearing, guide head, big	200	2
	014056	Guide head moving	235,260	1		013822	Exc. bearing, guide head, big	235,260,300	2
	013848	Guide head moving	300	1	9	001561	Allen screw M6x20	200	2
2	022963	Guide head fixed	200	1		001454	M8x25 SW screw	235,260	2
	014055	Guide head fixed	235,260	1		001717	M8x30 SW screw	300	2
	013850	Guide head fixed	300	1	10	001474	Washer 8	235,260,300	4
3	002709	Allen screw M5x45	300	2	11	002357	Hardened steel plate	200	4
	003642	Allen screw M5x35	200	2		001349	Hardened steel plate	235,260,300	4
	002207	Allen screw M5x50	235,260	2	12	001824	Allen screw M6x10 NH	200	2
4	002404	SW M5x20 screw	200	2		001673	Allen screw M8x12 NH	235,260,300	2
	001452	SW M5x25 screw	235,260,300	2	13	002387	M5x8 setting screw	200	2
5	001473	Washer 6	235,260,300	2		001457	M6x12 setting screw	235,260,300	2
6	002262	607 2Z bearing	200	4	14	002387	M5x8 setting screw	200	2
	001405	609 2Z bearing	235,260,300	4		001924	M6x6 setting screw	235,260,300	2
7	022965	Exc. bearing, guide head, small	200	2	15	001351	Hardened steel blade guide 12x4	200-300	2
	013821	Exc. bearing, guide head, small	235,260,300	2	16	001402	Drain valve	200-300	2



### 11.1.1. Guide Head Assembly in ARG 330

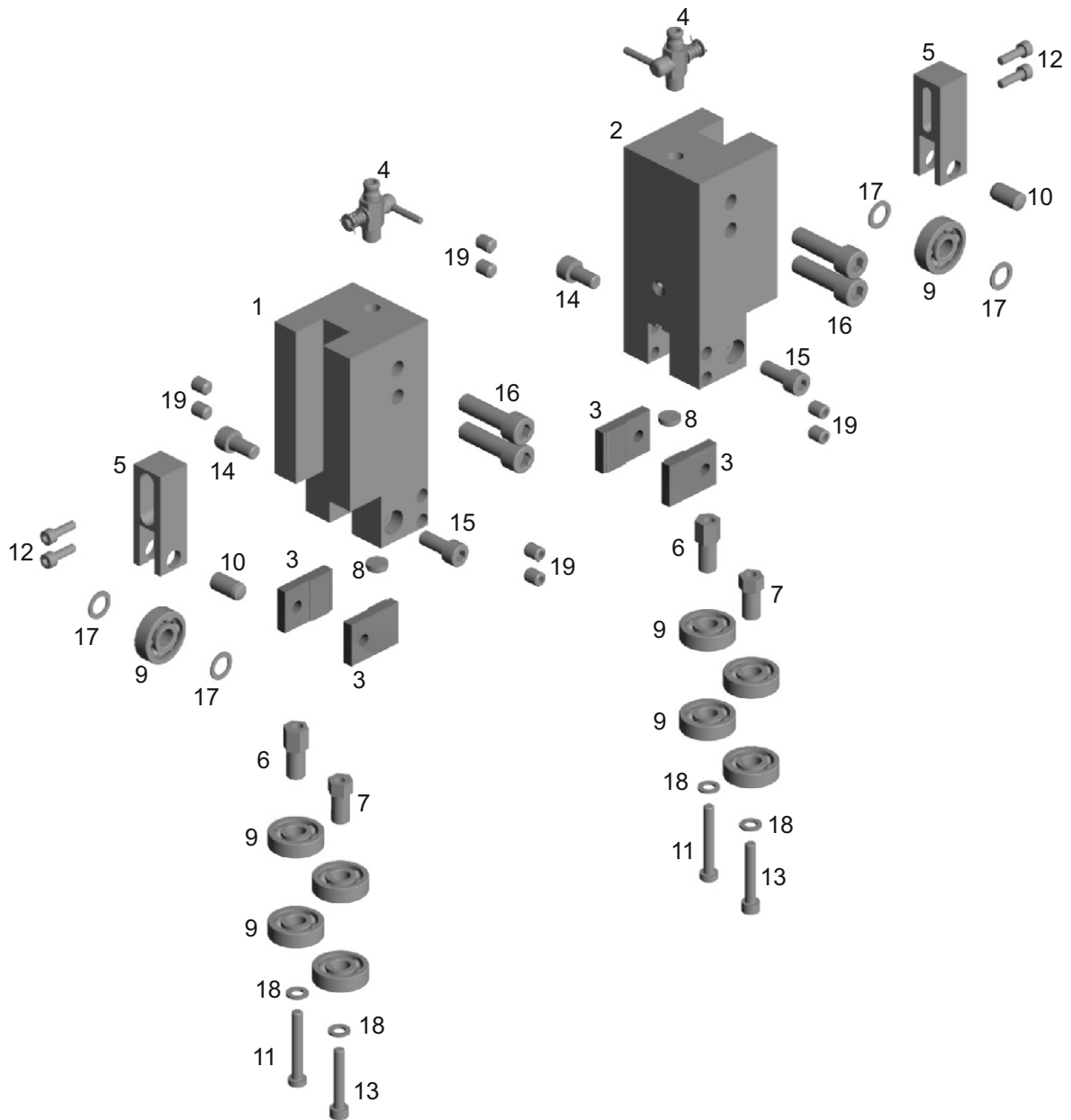

ver. 1.1.2016

Pos	Order number	Name	Type ARG	Pcs
1	013946	Guide head, moving	330	1
2	013947	Guide head, fixed	330	1
3	001997	Hardened steel plate	330	4
4	001402	Drain valve	330	2
5	001890	Guide head slider	330	2
6	014968	Exc. bearing, guide head, big	330	2
7	014967	Exc. bearing, guide head, small	330	2
8	001351	Hardened steel blade guide, round	330	2
9	001829	6200 - 2Z bearing	330	10
10	002044	Hardened pin 10x20	330	2
11	001676	Allen screw, low head, M6x40	330	2
12	001560	Allen screw M5x16	330	4
13	002042	Allen screw M6x35	330	2
14	001562	Allen screw M8x16	330	2
15	001441	Allen screw M8x20	330	2
16	001625	Allen screw M10x35	330	4
17	005036	Washer 10x16x1, flush	330	4
18	001473	Washer 6	330	4
19	001458	Worm Allen screw M8x10	330	8

## 11.2. Arm Assembly

### 11.2.1. Arm Assembly in ARG 200 Plus

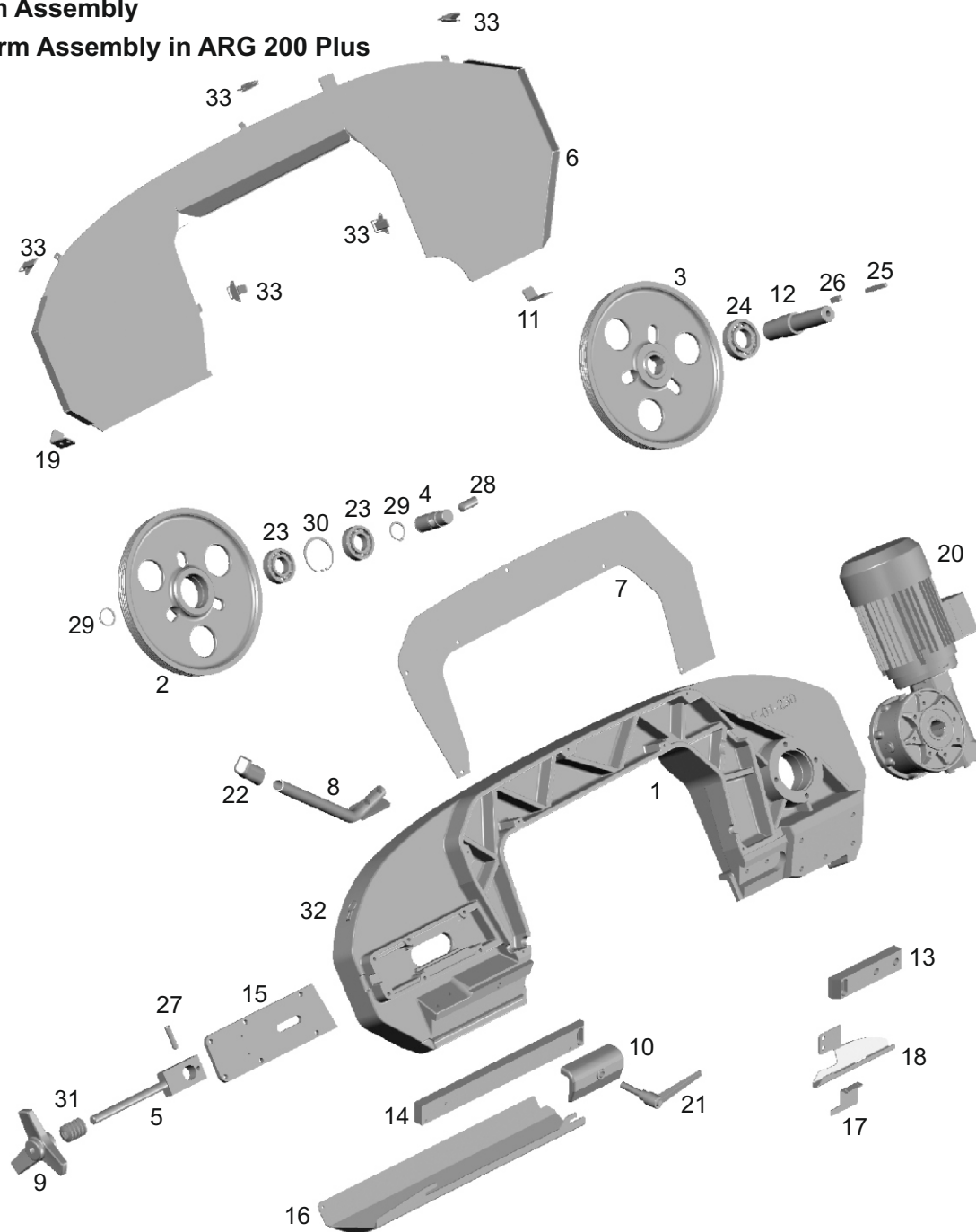

ver. 1.1.2018

Pos.	Order number	Name	Type ARG	Pcs	Pos.	Order number	Name	Type ARG	Pcs
1	019770	Arm	200	1	18	019777	Blade cover, fixed guide head	200	1
2	002971	Tensioning wheel	200	1	19	016194	Cover holder - front	200	1
3	002970	Blade wheel	200	1	20	009889	Drive	200	1
4	002235	Tensioning bolt	200	1	21	009055	Adjustable lever, M8x50	200	1
5	002991	Tensioning plate	200	1	22	001391	Rubber handle	200	1
6	002976	Back cover, arm	200	1	23	001404	Bearing 6006-2Z	200	2
7	006629	Upper cover	200	1	24	001406	Bearing 6007-2RS	200	1
8	018274	Lifting lever	200	1	25	023120	Tight spring 8e7x7x50	200	1
9	001340	Triangle	200	1	26	001488	Tight spring 10e7x8x30	200	1
10	002354	Clamp	200	1	27	001484	Hardened pin 10x40	200	1
11	016195	Cover stop - rear	200	1	28	001485	Hardened pin 16x40	200	1
12	006077	Shaft drive	200	1	29	001432	Retaining ring, outer	200	2
13	014740	Fixed rod	200	1	30	001436	Retaining ring, inner	200	1
14	004501	Movable rod	200	1	31	003826	Spring TP 31,5x16,3x1,2x2,1	200	10
15	002974	Tensioning system cover	200	1	32	009577	Cap	200	1
16	019778	Blade cover	200	1	33	002108	Angled latch	200	2
17	015881	Cover, fixed side rod	200	1					

### 11.2.2. Arm Assembly in ARG 235, ARG 260

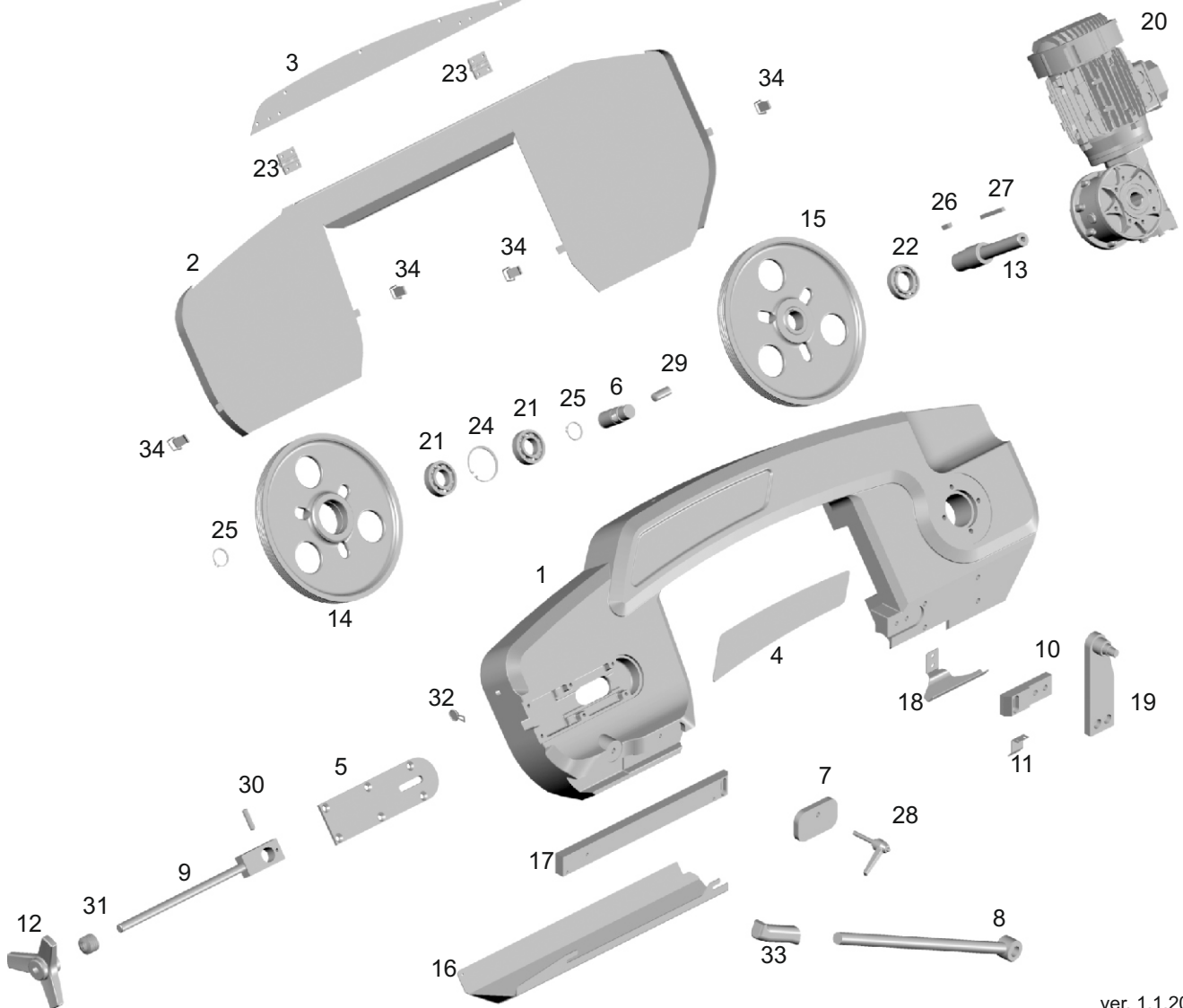

ver. 1.1.2018

Pos.	Order number	Name	Type ARG	Pcs	Pos.	Order number	Name	Type ARG	Pcs
1	024918	Arm 235	235	1	16	015768	Blade cover	235,260	1
	025548	Arm 260	260	1	17	014057	Movable rod	235,260	1
2	024919	Back cover, arm	235	1	18	015882	Blade cover, fixed guide head	235	1
	025549	Back cover, arm	260	1		025555	Blade cover, fixed guide head	260	1
3	024920	Upper cover	235	1	20	021914	Drive MRT60, i=30	235	1
	025550	Upper cover	260	1		024891	Drive MRT60, i=30	235 F	1
4	024921	Underlying metal sheet	235,260	1		021915	Drive MRT70, i=30	260	1
5	024922	Tensioning system cover	235,260	1		021916	Drive MRT60, i=25	260 F	1
6	024923	Tensioning bolt	235	1	21	001626	Bearing 6206-2Z	235,260	2
	025554	Tensioning bolt	260	1	22	001406	Bearing 6007-2RS1	235	1
7	024924	Clamp	235,260	1		001627	Bearing 6207-2RS1	260	1
8	024925	Lifting lever	235,260	1	23	024973	Hinge	235,260	2
9	024926	Tensioning plate	235,260	1	24	001437	Retaining ring, inner ø 62	235,260	1
10	024928	Fixed rod	235	1	25	001432	Retaining ring, outer ø 30	235,260	2
	002183	Fixed rod	260	1	26	001488	Tight spring 10e7x8x25	235,260	1
11	024929	Bearing cover	235	1	27	006699	Tight spring 8e7x7x70	235,260	1
	015880	Bearing cover	260	1	28	009055	Adjustable lever, M8x50	235,260	1
12	001340	Triangle	235,260	1	29	001485	Hardened pin 16x40	235,260	1
13	024931	Shaft drive	235	1	30	001484	Hardened pin 10x40	235,260	1
	025552	Shaft drive	260	1	31	001483	TP 31,5x16,3x1,8x2,5	235,260	10
14	001670	Tensioning wheel	235	1	32	009577	Cap	235,260	1
	025559	Tensioning wheel	260	1	33	001391	Rubber handle	235,260	1
15	001342	Blade wheel	235	1	34	002108	Angled latch	235,260	4
	025558	Blade wheel	260	1					

### 11.2.3. Arm Assembly in ARG 300

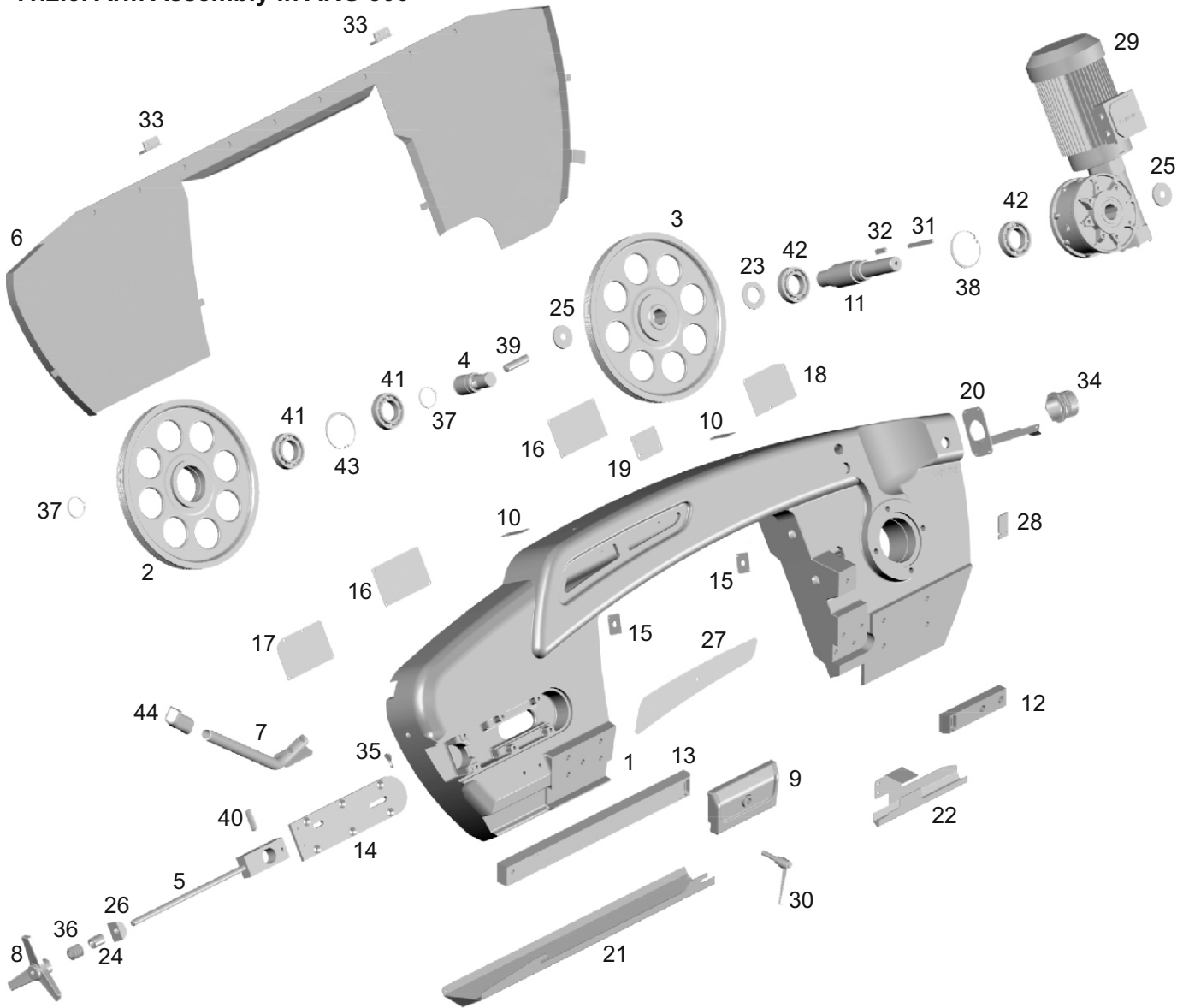

ver. 1.9.2017

Pos.	Order number	Name	Type ARG	Pcs	Pos.	Order Number	Name	Type ARG	Pcs
1	023378	Arm	300	1	23	023377	Ring	300	1
2	002161	Tensioning wheel	300	1	24	023371	Spacer	300	1
3	002160	Blade wheel	300	1	25	014108	Washer	300	2
4	023368	Tensioning bolt	300	1	26	023370	Support plate, round	300	1
5	023369	Tensioning plate	300	1	27	023825	Underlying metal sheet	300	1
6	023429	Back cover, arm	300	1	28	018708	Limit switch washer	300	1
7	023372	Lifting lever	300	1	29	021917	El. drive MRT80-25-FT-RL-90/115	300	1
8	001340	Triangle	300	1	30	011205	Adjustable lever, M12x50	300	1
9	023379	Clamp	300	1	31	011885	Tight spring 10x 8x 80	300	1
10	020473	Cover stop - rear	300	2	32	005423	Tight spring 12x 8x 30	300	1
11	002172	Shaft drive	300	1	33	021170	Hinge	300	2
12	021701	Fixed rod	300	1	34	014591	Bushing	300	1
13	013851	Movable rod	300	1	35	009577	Cap	300	1
14	023367	Tensioning system cover	300	1	36	001483	TP 31,5x16,3x1,8x2,5	300	10
15	020774	Cooling cover	300	2	37	001432	Retaining ring, outer ø 30	300	2
16	023373	Arm cover 1	300	2	38	001893	Retaining ring, inner ø 90	300	1
17	023374	Arm cover 2	300	1	39	001485	Hardened pin 16x40	300	1
18	023375	Arm cover 3	300	1	40	002384	Hardened pin 10x45	300	1
19	023376	Arm cover 4	300	1	41	001626	Ball bearing 6206-2Z	300	2
20	023495	Arm cover rear	300	1	42	002186	Ball bearing 6308-2Z	300	2
21	024291	Blade cover	300	1	43	001437	Retaining ring, inner ø 62	300	1
22	024251	Blade cover, fixed guide head	300	1	44	001391	Rubber handle	300	1

### 11.2.4. Arm assembly in ARG 330

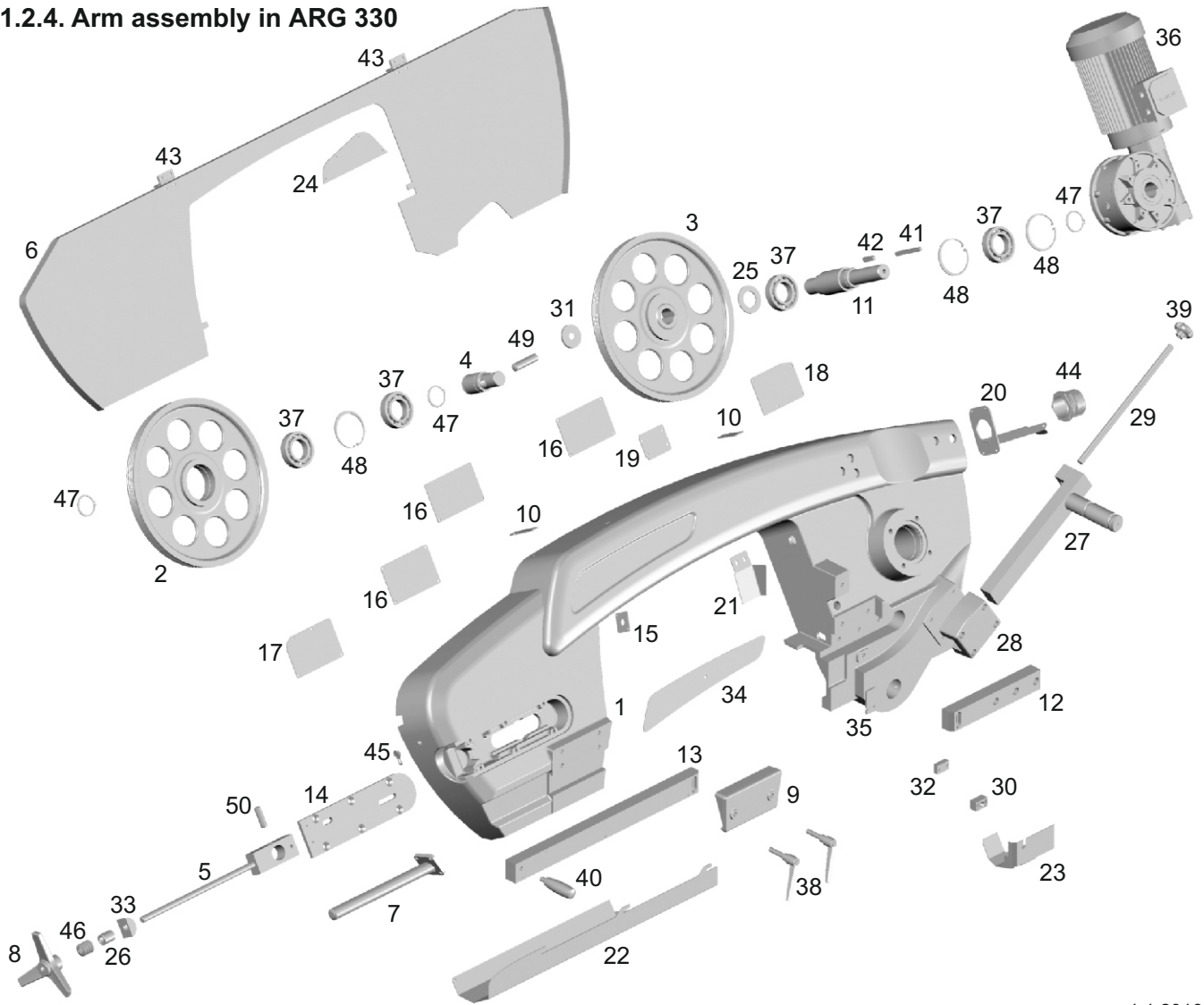

ver. 1.1.2016

Pos	Order number	Name	Type ARG	Pcs	Pos	Order number	Name	Type ARG	Pcs
1	020841	Arm 330	330	1	26	022309	Spacer	330	1
2	012516	Tensioning wheel	330	1	27	020826	Upper spring holder	330	1
3	012515	Blade wheel	330	1	28	020639	Spring holder, movable	330	1
4	001767	Tensioning bolt	330	1	29	020825	Spring holder screw	330	1
5	014230	Tensioning plate	330	1	30	022736	Guide head cover column	330	1
6	020830	Back cover, arm	330	1	31	015852	Pulley washer	330	1
7	020693	Lifting lever	330	1	32	022737	Column washer	330	1
8	001930	Triangle	330	1	33	020824	Support plate, round	330	1
9	020640	Clamp	330	1	34	020428	Underlying metal sheet, logo	330	1
10	020473	Back cover latch	330	2	35	018708	Safety switch washer 5	330	1
11	020776	Shaft drive	330	1	36	021918	Electric motor TM2-100-4L 3.0kW	330	1
12	020828	Fixed rod	330	1	37	001906	6210 - 2Z bearing	330	4
13	020778	Movable rod	330	1	38	011205	Adjustable lever M12x50	330	2
14	020450	Tensioning system cover	330	1	39	005140	Plastic triangle	330	1
15	020774	Cooling cap	330	1	40	020937	M12 screw, handle	330	1
16	020421	Arm cap 1	330	3	41	001765	Tight spring 10e7x8x100	330	1
17	020422	Arm cap 2	330	1	42	023204	Tight spring 12e7x8x40	330	1
18	020423	Arm cap 3	330	1	43	021170	Hinge	330	2
19	020424	Arm cap 4	330	1	44	014591	Bushing	330	1
20	020690	Arm cap, back - flange	330	1	45	009577	Cap KR 12	330	1
21	020691	Cable cover	330	1	46	001483	Disc spring 31.5x16.3x1.8x2.5	330	10
22	020692	Front rod cover - 330 plus	330	1	47	001892	Retaining ring, outer, ø 50	330	3
23	022738	Fixed guide head cover	330	1	48	001893	Retaining ring, inner, ø 90	330	3
24	020689	Protective cover	330	1	49	001839	Hardened pin 20x80	330	1
25	020777	Ring spacer	330	1	50	006845	Hardened pin 16x55	330	1

### 11.3. Oil Damper Assembly

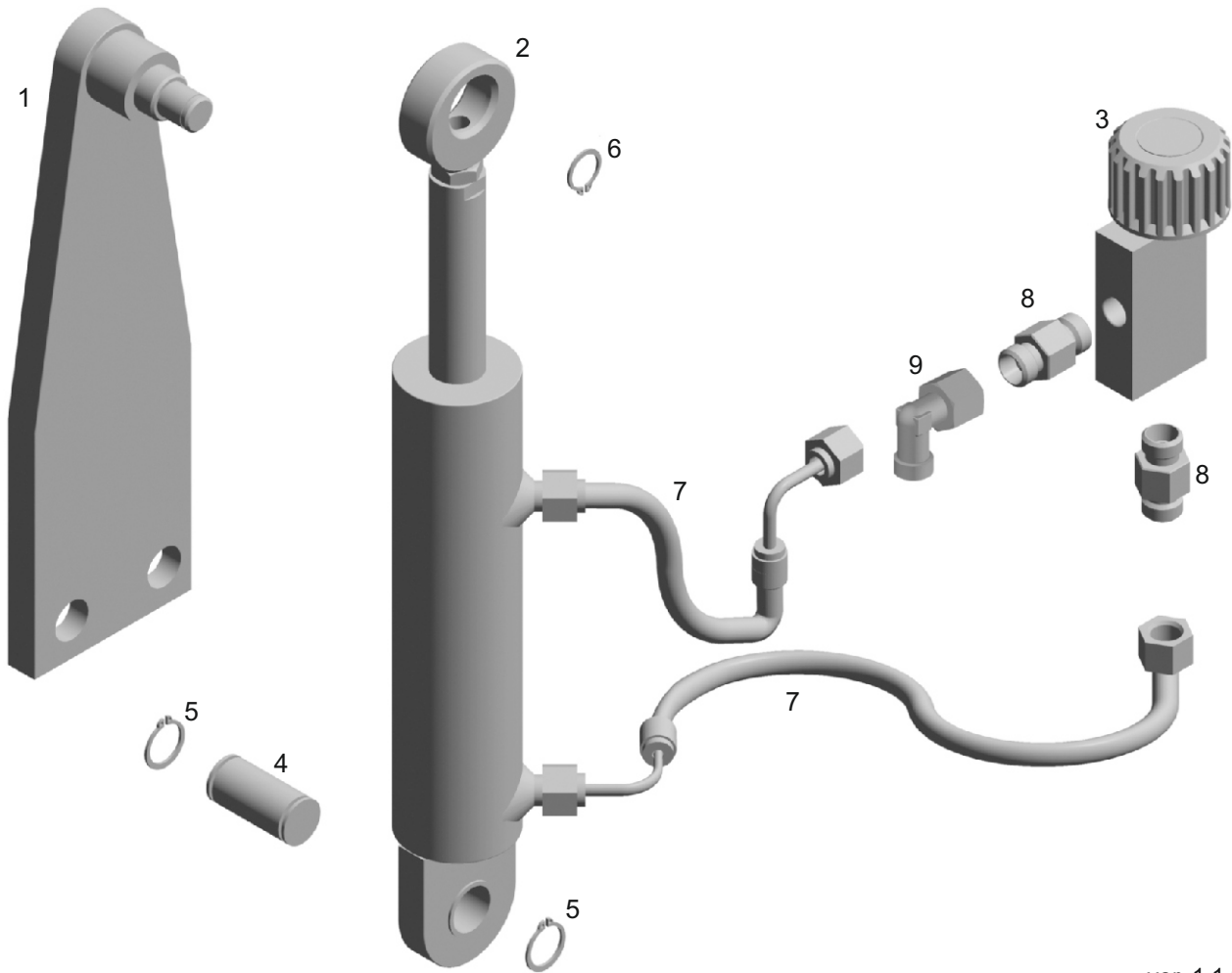

ver. 1.1.2018

Pos.	Order number	Name	Type ARG	Pcs
1	006462	Gibbet	200+	1
	024930	Gibbet	235	1
	024927	Gibbet	235+	1
	017218	Gibbet	260+E	1
	014992	Gibbet	260	1
	014994	Gibbet	260+	1
	014996	Gibbet	300	1
	014998	Gibbet	300+	1
	021041	Gibbet	330	1
	025393	Gibbet	330+	1
2	006571	Hydraulic cylinder	200,235	1
	006573	Hydraulic cylinder	250,300	1
	020915	Hydraulic cylinder	330	1
3	006587	Butterfly valve	200-330	1
4	001386	Hydraulics pin	200-300	1
5	001429	Retaining ring KR 12, outer	200-300	2
	001431	Retaining ring KR 20, outer	330	1
6	001430	Retaining ring KR 15, outer	200-300	1
	001431	Retaining ring KR 20, outer	330	1
7	001881	Hydraulic hose DN 6x2500, 90	200+, 235	2
	001696	Hydraulic hose DN 8x2500, 90, M16x1.5, 40bar	260	2
	007141	Hydraulic hose DN 8x3000, 90, M16x1.5, 40bar	300	2
	020907	Hydraulic hose DN 8x4500, 90 16, ARG330	330	2
	8	001986	Straight connector GES 8L/R	200-235
8	002277	Straight connector GES 10L/R	260-330	2
	003569	Hydraulic oil HV 46	200-330	1 l
	9	006953	Adjustable connector EWSD 10L	330

### 11.4.2. The Table, Joint and Vice in ARG 235 Assembly

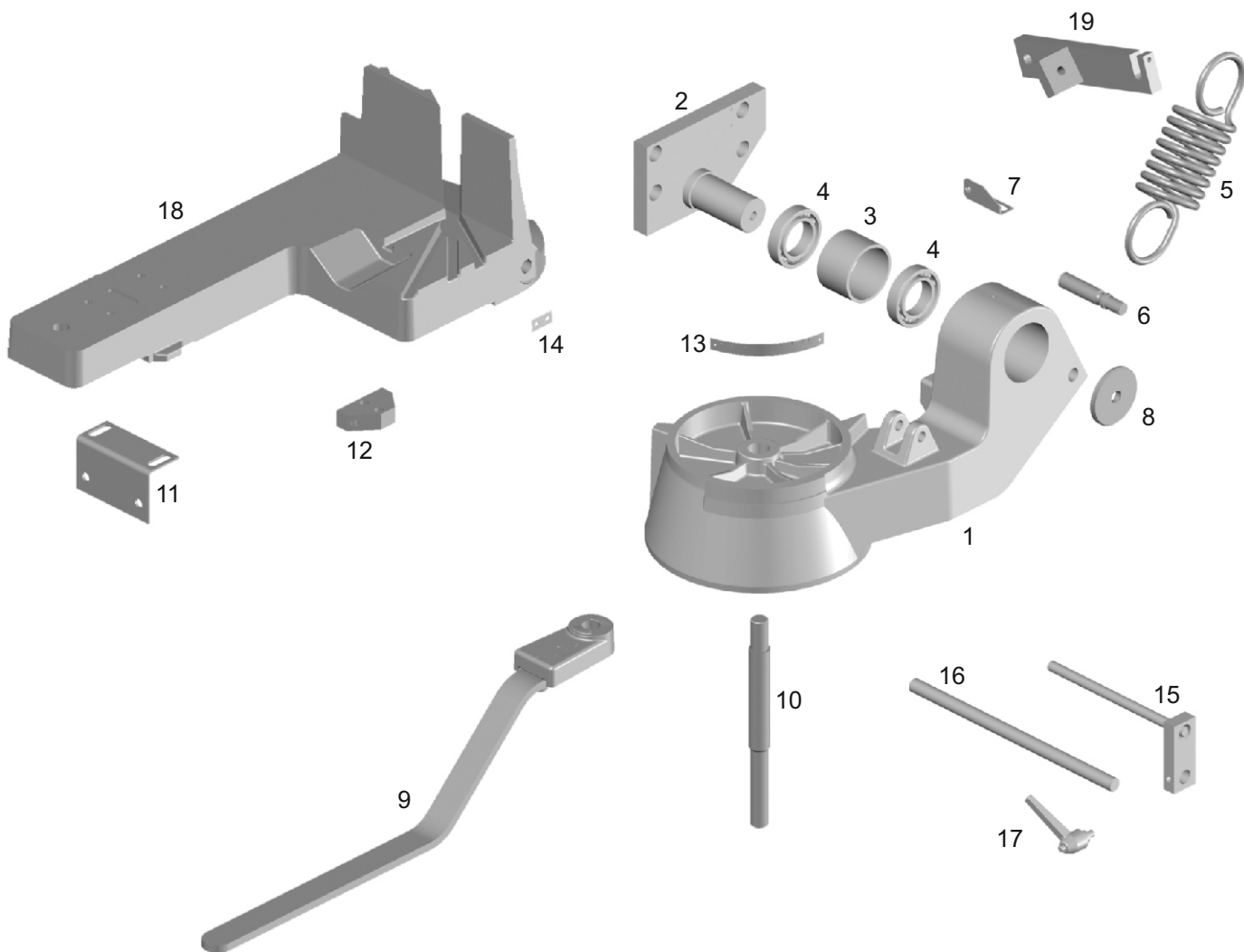

ver. 1.1.2018

Pos	Order number	Name	Type ARG	Pcs
1	017938	Turntable	235	1
2	017940	Joint	235	1
3	009449	Tube spacer	235	1
4	002263	6008-2Z ball bearing	235	2
5	015914	Tension spring	235	1
6	016189	Spring pin, turntable	235	1
7	002353	End switch stop	235	1
8	002332	Joint cap	235	1
9	017962	Table lever	235	1
10	017941	Screw, table	235	1
11	017946	Vice console, upper	235	1
12	017945	Stop block	235	1
13	017671	Angular plate 60 °	235	1
14	001421	Measuring plate	235	1
15	017944	Stop with a rod	235	1
16	017943	Stop rod	235	1
17	015252	Adjustable lever M8x10	235	1
18	017936	Vice body	235	1
19	017934	Spring tensioning	235	1

### 11.4.3. The Table, Turntable, Joint and Vice Assembly in ARG 200 plus, ARG 235 plus, ARG 260 plus E

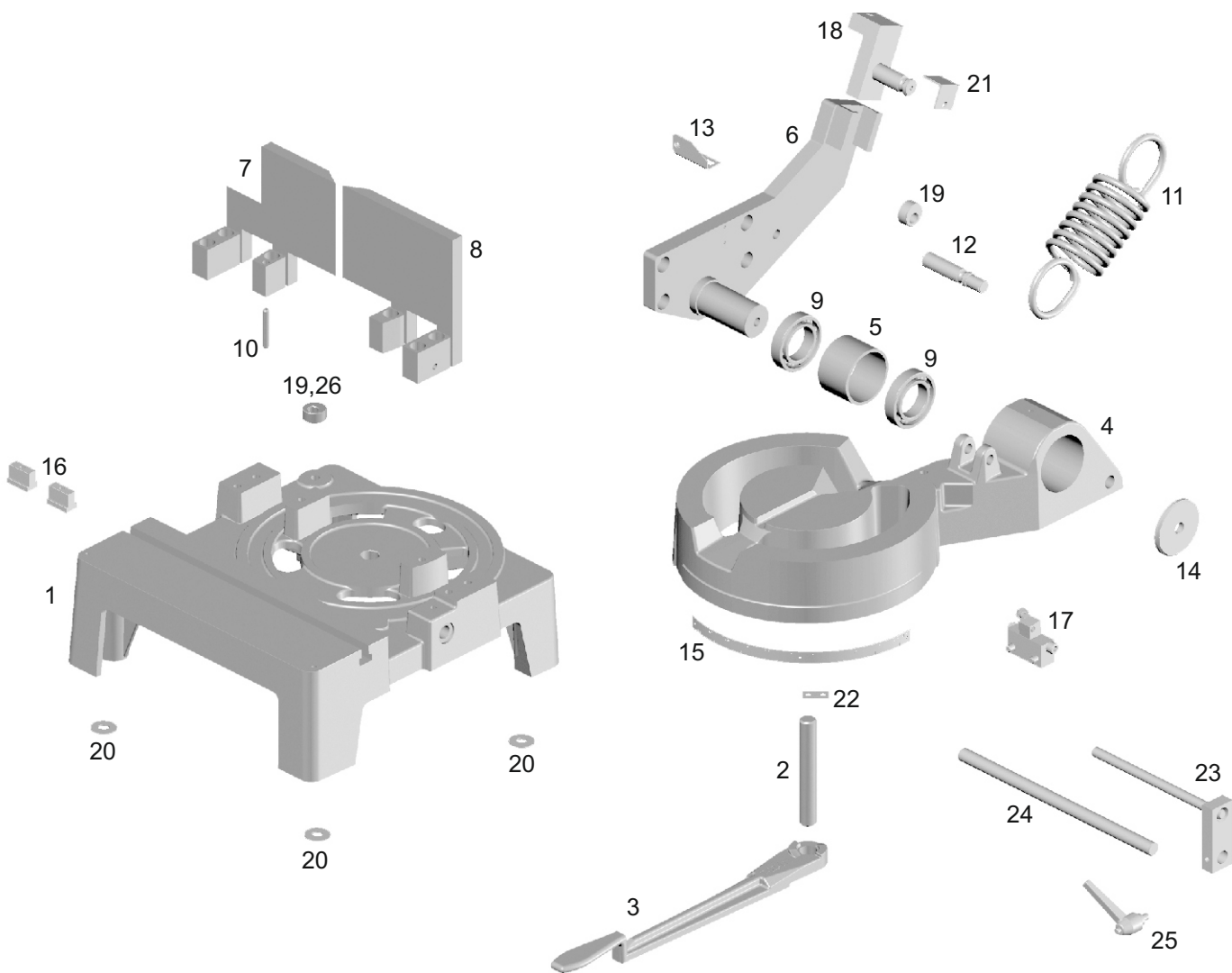

ver. 1.1.2018

Pos	Order number	Name	Type ARG	Pcs	Pos	Order number	Name	Type ARG	Pcs
1	016114	Table body	200+ - 260+E	1	14	002332	Joint cap	200+ - 260+E	1
2	006526	Turntable pin	200+ - 260+E	1	15	002358	Angular plate	200+ - 260+E	1
3	009060	Table lever	200+ - 260+E	1	16	013378	Nut	235+,260+E	2
4	016112	Turntable	200+,235+	1		009146	Nut	200+	2
	017220	Turntable	260+E	1	17	013577	Table stop, 90°	200+ - 260+E	1
5	009449	Tube spacer	200+ - 260+E	1	18	016190	Spring shank	200+ - 260+E	1
6	016188	Joint	200+ - 235+	1	19	001579	Excentr.	200+,235+	2
	017219	Joint	260+E	1		001579	Excentr.	260+E	1
7	003539	Left jaw	200+ - 260+E	1	20	005643	Rubber gasket under the table	200+ - 260+E	4
8	005053	Right jaw	200+ - 260+E	1	21	002210	Spring angle	200+ - 260+E	1
9	002263	6008-2Z ball bearing	200+ - 260+E	2	22	001421	Measuring plate	200+ - 260+E	1
10	023168	8x50 flexible pin	200+ - 260+E	1	23	009450	Stop with a rod	200+ - 260+E	1
11	015914	Tension spring	200+ - 260+E	1	24	017943	Stop rod	200+ - 260+E	1
12	016189	Spring pin, turntable	200+ - 260+E	1	25	011540	Adjustable lever M8x16	200+ - 260+E	1
13	002353	End switch stop	200+,235+	1	26	021189	Excentr.	260+E	1
	018091	End switch stop	260+E	1					



### 11.4.4. Vice Assembly in ARG 200 plus

ver. 1.1.2016

Pos	Order number	Name	Type ARG	Pcs
1	009427	Vice body plus	200+	1
2	009416	Vice cylinder	200+	1
3	009446	Movable jaw plate plus	200+	1
4	006862	Star nut	200+	1
5	009055	Adjustable lever, M8x50	200+	1
6	004241	5x28 flexible pin	200+	1
7	009146	Rectangular nut	200+	1

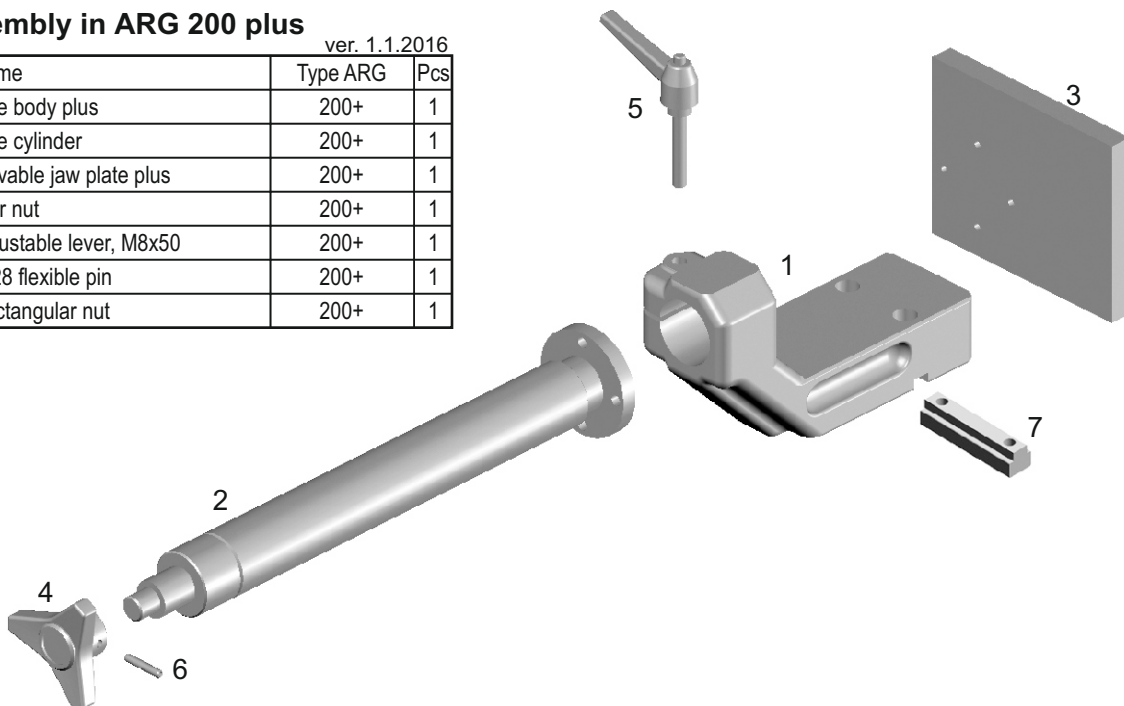

### 11.4.5. Vice Assembly in ARG 235, 235 plus, ARG 260 plus E

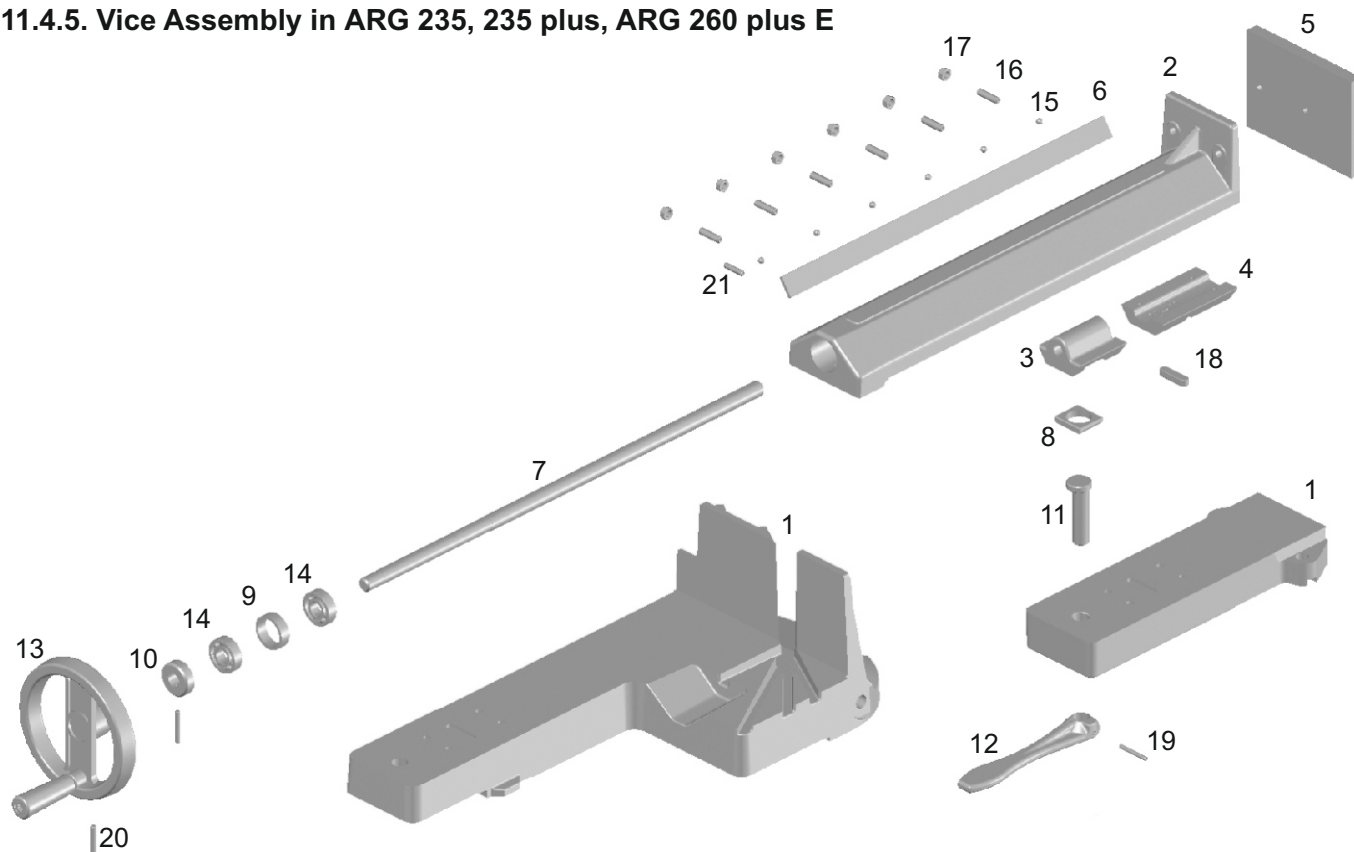

ver. 1.1.2018

Pos	Order number	Name	Type ARG	Pcs	Pos	Order number	Name	Type ARG	Pcs
1	014560	Vice body	235+,260+E	1	11	001365	Quick-clamping excentr.	235,235+,260+E	1
	017936	Vice body	235	1	12	011366	Quick-clamping lever plus	235,235+,260+E	1
2	016263	Movable jaw	235,235+,260+E	1	13	002111	Vice handwheel with a crank	235,235+,260+E	1
3	014555	Trapezoidal nut quick-clamping	235,235+,260+E	1	14	001720	Ball bearing 6203-2Z	235,235+,260+E	2
4	014556	Vice guidance, quick	235,235+,260+E	1	15	010288	Ball, bearing	235,235+,260+E	6
5	014557	Movable jaw plate	235,235+,260+E	1	16	001617	Worm Allen bolt, M8x30	235,235+,260+E	6
6	014558	Groove bar	235,235+,260+E	1	17	001712	Locking nut M8 8 zn	235,235+,260+E	6
7	018094	Trapezoidal screw	235,235+,260+E	1	18	014240	Tight spring 10e7x8x40	235,235+,260+E	1
8	011363	Head, quick-clamping	235,235+,260+E	1	19	009552	5x40 flexible pin	235,235+,260+E	2
9	011364	Spacer ring	235,235+,260+E	1	20	002642	6x40 flexible pin	235	1
10	011365	Support ring	235,235+,260+E	1	21	009552	5x40 flexible pin	235+,260+E	1

### 11.4.6. The Table, Joint and Vice Assembly in ARG 250, ARG 300

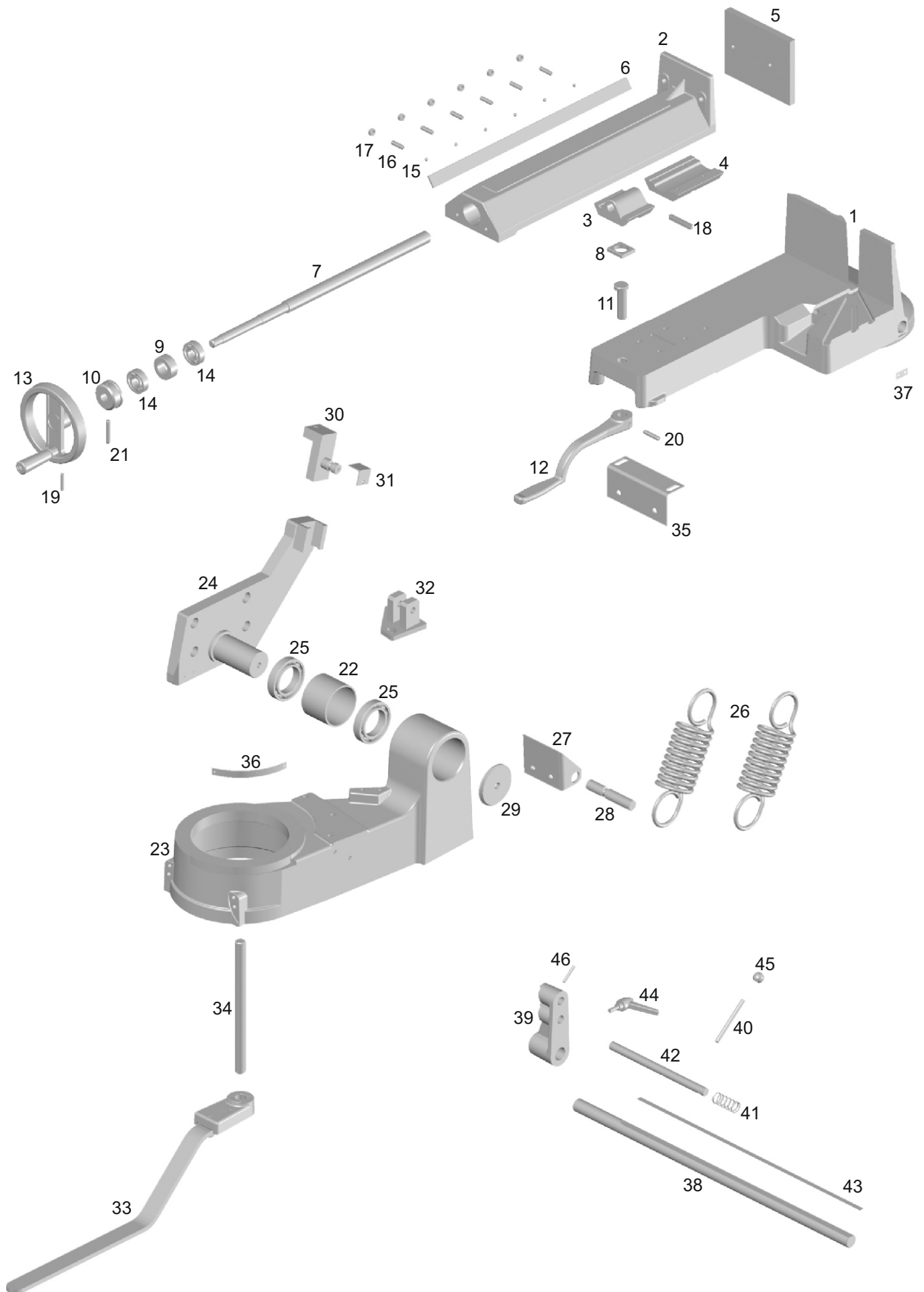

Pos	Order number	Name	Type ARG	Pcs	Pos	Order number	Name	Type ARG	Pcs
1	002177	Vice body	260	1	25	006474	6010-2Z ball bearing	260	2
2	002178	Movable jaw	260	1	26	001368	Tension spring	260	1
3	008717	Trapezoidal nut	260	1	27	001372	U 100	260	1
4	001713	Vice guidance	260	1	28	001373	Spring pin	260	1
5	016073	Movable jaw plate	260	1	29	013855	Joint cap	260	1
6	002187	Groove bar	260	1	30	015310	Spring shank	260	1
7	006958	Trapezoidal screw	260	1	31	002210	Spring angle	260	1
8	001366	Head, quick-clamping	260	1	32	014987	Hydraulics holder, lower	260	1
9	008715	Spacer ring	260	1	33	017962	Table lever	260	1
10	008716	Support ring	260	1	34	001360	Screw, table, M20	260	1
11	001365	Quick-clamping excentr.	260	1	35	006359	Vice console, upper	260	1
12	001357	Quick-clamping lever	260	1	36	008396	Angular plate 60 °	260	1
13	002111	Vice handwheel with a crank	260	1	37	001421	Measuring plate	260	1
14	001408	6204-2Z ball bearing	260	2	38	015415	Stop rod, long	260	1
15	001711	Ball, bearing 6	260	6	39	015416	Adjustable stop body	260	1
16	001617	Worm screw, punched M8x30	260	6	40	015417	Stop rod lever	260	1
17	001712	Locking nut M8	260	6	41	015418	Compression spring 2x22x60	260	1
18	004390	Tight spring 10e7x8x60	260	1	42	015419	Stop rod, short	260	1
19	014238	6x36 flexible pin	260	1	43	009295	Label, stop gauge, mm	260	1
20	009597	8x40 flexible pin	260	1	44	011540	Adjustable lever M8x20	260	1
21	023168	8x50 flexible pin	260	1	45	001552	Ball 20 M8	260	1
22	009587	Tube spacer	260	1	46	002642	6x40 flexible pin	260	1
23	008600	Turntable - universal	260	1					
24	016347	Joint	260	1					

Pos	Order number	Name	Type ARG	Pcs	Pos	Order number	Name	Type ARG	Pcs
1	015391	Vice body	300	1	25	009605	Tapered roller bearing 32010 X	300	2
2	002665	Movable jaw	300	1	26	001368	Tension spring	300	2
3	008717	Trapezoidal nut	300	1	27	001372	U 100	300	1
4	001713	Vice guidance	300	1	28	002168	Spring pin	300	1
5	002666	Movable jaw plate	300	1	29	013855	Joint cap	300	1
6	002669	Groove bar	300	1	30	015539	Spring shank	300	1
7	013980	Trapezoidal screw	300	1	31	002210	Spring angle	300	1
8	001366	Head, quick-clamping	300	1	32	014987	Hydraulics holder, lower	300	1
9	008715	Spacer ring	300	1	33	021033	Table lever	300	1
10	008716	Support ring	300	1	34	001360	Screw, table, M20	300	1
11	001365	Quick-clamping excentr.	300	1	35	006359	Vice console, upper	300	1
12	001357	Quick-clamping lever	300	1	36	008396	Angular plate 60 °	300	1
13	002111	Vice handwheel with a crank	300	1	37	001421	Measuring plate	300	1
14	001408	6204-2Z ball bearing	300	2	38	015415	Stop rod, long	300	1
15	001711	Ball, bearing 6	300	7	39	015416	Adjustable stop body	300	1
16	001617	Worm screw, punched M8x30	300	7	40	015417	Stop rod lever	300	1
17	001712	Locking nut M8	300	7	41	015418	Compression spring 2x22x60	300	1
18	004390	Tight spring 10e7x8x60	300	1	42	015419	Stop rod, short	300	1
19	014238	6x36 flexible pin	300	1	43	009295	Label, stop gauge, mm	300	1
20	009597	8x40 flexible pin	300	1	44	011540	Adjustable lever M8x20	300	1
21	023168	8x50 flexible pin	300	1	45	001552	Ball 20 M8	300	1
22	009588	Tube spacer	300	1	46	002642	6x40 flexible pin	300	1
23	008600	Turntable - universal	300	1					
24	015401	Joint	300	1					

11.4.7. The Table, Turntable, Joint and Vice Assembly in ARG 250 plus, ARG 300 plus

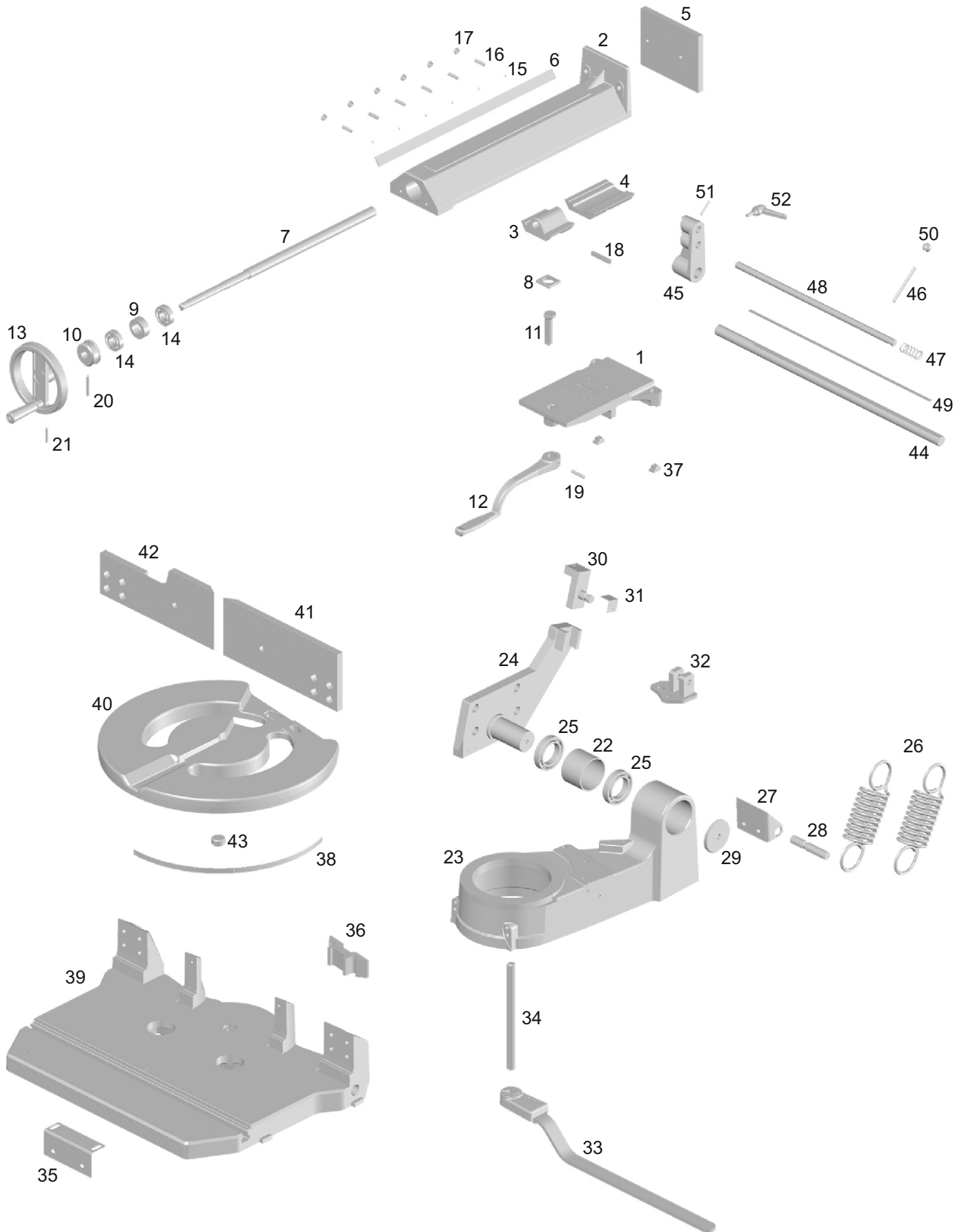

Pos	Order number	Name	Type ARG	Pcs	Pos	Order number	Name	Type ARG	Pcs
1	015394	Vice body	260+	1	28	001373	Spring pin	260+	1
2	002178	Movable jaw, shell	260+	1	29	013855	Joint cap	260+	1
3	008717	Trapezoidal nut	260+	1	30	015310	Spring shank	260+	1
4	001713	Vice guidance	260+	1	31	002210	Spring angle	260+	1
5	016073	Movable jaw plate	260+	1	32	014988	Hydraulics holder, lower	260+	1
6	002187	Groove bar	260+	1	33	002158	Table lever, mounted	260+	1
7	006958	Trapezoidal screw	260+	1	34	001360	Screw, table, M20	260+	1
8	001366	Head, quick-clamping	260+	1	35	006359	Vice console, upper	260+	1
9	008715	Spacer ring	260+	1	36	015411	Table head	260+	1
10	008716	Support ring	260+	1	37	001496	T Nut	260+	2
11	001365	Quick-clamping excentr.	260+	1	38	001498	Angular plate	260+	1
12	001357	Quick-clamping lever	260+	1	39	015406	Table plate	260+	1
13	002111	Vice handwheel with a crank	260+	1	40	015408	Turntable	260+	1
14	001408	6204-2Z ball bearing	260+	2	41	015409	Right jaw	260+	1
15	001711	Ball, bearing 6	260+	6	42	015410	Left jaw	260+	1
16	001617	Worm screw, punched M8x30	260+	6	43	009603	Aligning nut	260+	1
17	001712	Locking nut M8	260+	6	44	015415	Stop rod, long	260+	1
18	004390	Tight spring 10e7x8x60	260+	1	45	015416	Adjustable stop body	260+	1
19	009597	8x40 flexible pin	260+	1	46	015417	Stop rod lever	260+	1
20	023168	8x50 flexible pin	260+	1	47	015418	Compression spring 2x22x60	260+	1
21	014238	6x36 flexible pin	260+	1	48	015420	Stop rod, short	260+	1
22	009587	Tube spacer	260+	1	49	009295	Label, stop gauge	260+	1
23	008600	Turntable	260+	1	50	001552	Ball 20 M8	260+	1
24	016347	Joint	260+	1	51	002642	6x40 flexible pin	260+	1
25	006474	6010-2Z ball bearing	260+	2	52	011540	Adjustable lever M8x20	260+	1
26	001368	Tension spring	260+	1					
27	001372	U 100	260+	1					

Pos	Order number	Name	Type ARG	Pcs	Pos	Order number	Name	Type ARG	Pcs
1	015394	Vice body	300+	1	28	002168	Spring pin	300+	1
2	002665	Movable jaw, shell	300+	1	29	013855	Joint cap	300+	1
3	008717	Trapezoidal nut	300+	1	30	015539	Spring shank	300+	1
4	001713	Vice guidance	300+	1	31	002210	Spring angle	300+	1
5	002666	Movable jaw plate	300+	1	32	014988	Hydraulics holder, lower	300+	1
6	002669	Groove bar	300+	1	33	002158	Table lever, mounted	300+	1
7	013980	Trapezoidal screw	300+	1	34	001360	Screw, table, M20	300+	1
8	020632	Head, quick-clamping	300+	1	35	006359	Vice console, upper	300+	1
9	008715	Spacer ring	300+	1	36	015411	Table head	300+	1
10	008716	Support ring	300+	1	37	001496	T Nut	300+	2
11	001365	Quick-clamping excentr.	300+	1	38	002135	Angular plate	300+	1
12	001357	Quick-clamping lever	300+	1	39	015397	Table plate	300+	1
13	002111	Vice handwheel with a crank	300+	1	40	015398	Turntable	300+	1
14	001408	6204-2Z ball bearing	300+	2	41	015399	Right jaw	300+	1
15	001711	Ball, bearing 6	300+	7	42	015400	Left jaw	300+	1
16	006429	Worm screw, punched M8x35	300+	7	43	009603	Aligning nut	300+	1
17	001712	Locking nut M8	300+	7	44	015415	Stop rod, long	300+	1
18	004390	Tight spring 10e7x8x60	300+	1	45	015416	Adjustable stop body	300+	1
19	009597	8x40 flexible pin	300+	1	46	015417	Stop rod lever	300+	1
20	023168	8x50 flexible pin	300+	1	47	015418	Compression spring 2x22x60	300+	1
21	014238	6x36 flexible pin	300+	1	48	015422	Stop rod, short	300+	1
22	009588	Tube spacer	300+	1	49	009295	Label, stop gauge	300+	1
23	008600	Turntable	300+	1	50	001552	Ball 20 M8	300+	1
24	015401	Joint	300+	1	51	002642	6x40 flexible pin	300+	1
25	009605	Tapered roller bearing 32010 X	300+	2	52	011540	Adjustable lever M8x20	300+	1
26	001368	Tension spring	300+	2					
27	001372	U 100	300+	1					

### 11.4.8. The Table, Joint and Vice in ARG 330 Assembly

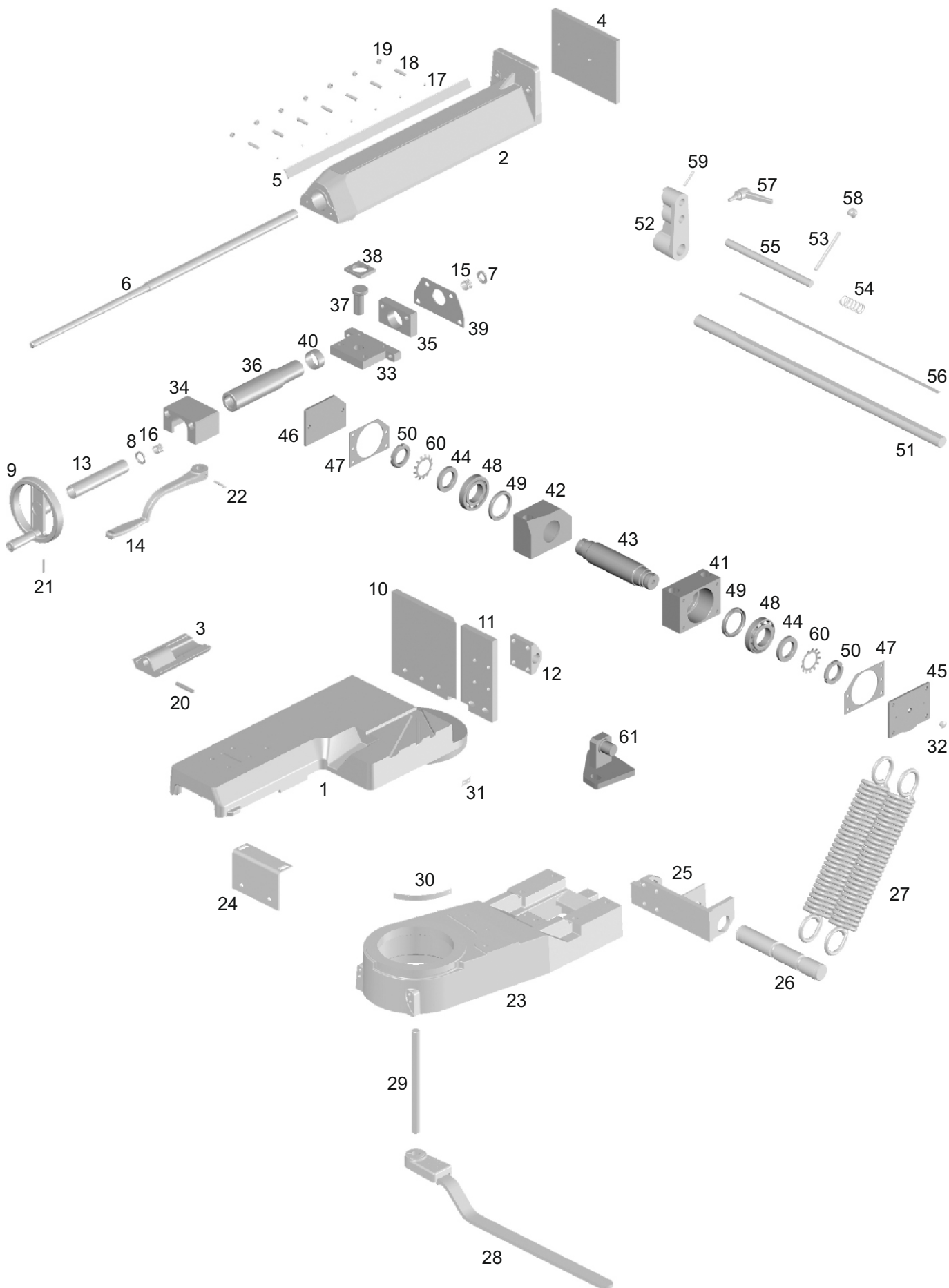

Pos	Order number	Name	Type ARG	Pcs	Pos	Order number	Name	Type ARG	Pcs
1	020832	Vice body	330	1	32		Cap	330	1
2	002665	Movable jaw	330	1	33	020627	Base	330	1
3	020836	Trapezoidal nut	330	1	34	020628	Enclosure	330	1
4	020626	Movable jaw plate	330	1	35	020629	Back plate	330	1
5	002669	Groove bar	330	1	36	020630	Tube	330	1
6	020624	Trapezoidal screw	330	1	37	020631	Quick-clamping excentr.	330	1
7	008874	Trapezoidal screw ring 1	330	1	38	020632	Head, quick-clamping	330	1
8	002148	Trapezoidal screw ring 2	330	1	39	020662	Washer	330	1
9	002111	Vice handwheel with a crank	330	1	40	004210	Enclosure	330	1
10	020833	Table plate, left	330	1	41	021574	Arm support housing	330	1
11	020834	Table plate, right	330	1	42	022242	Arm support housing	330	1
12	020835	Stop holder	330	1	43	020729	Arm support shaft	330	1
13	020625	Retaining roller	330	1	44	020728	Ring spacer	330	2
14	001357	Quick-clamping lever	330	1	45	021573	Lid 3	330	1
15	001836	Needle bearing K20x24x17	330	1	46	022243	Lid 4	330	1
16	001835	Needle bearing K18x22x17	330	1	47	021871	Sealing	330	2
17	001711	Ball, bearing 6	330	7	48	020618	Tapered roller bearing 30209	330	2
18	006429	Worm screw, punched, M8x35	330	7	49	020716	Radial shaft seal 52x72x8	330	2
19	001712	Locking nut M8	330	7	50	017808	KM 8 Nut	330	2
20	004390	Tight spring 10e7x8x60	330	1	51	015415	Stop rod, long	330	1
21	014238	6x36 flexible pin	330	1	52	015416	Adjustable stop body	330	1
22	002642	6x40 flexible pin	330	1	53	015417	Stop rod lever	330	1
23	020770	Turntable	330	1	54	015418	Compression spring 2x22x60	330	1
24	021417	Vice console, upper	330	1	55	015419	Stop rod, short	330	1
25	020621	Spring pin holder	330	1	56	009295	Label, stop gauge	330	1
26	002091	Spring pin	330	1	57	011540	Adjustable lever M8x20	330	1
27	001950	Tension spring	330	2	58	001552	Ball 20 M8	330	1
28	002158	Table lever	330	1	59	002642	6x40 flexible pin	330	1
29	020852	Screw, table, M20	330	1	60	020620	MB 8 Washer	330	2
30	008396	Angular plate	330	1	61	014989	Hydraulics holder, lower	330	1
31	001421	Measuring plate	330	1					

### 11.4.9. The Table, Turntable, Joint and Vice Assembly in ARG 330 plus

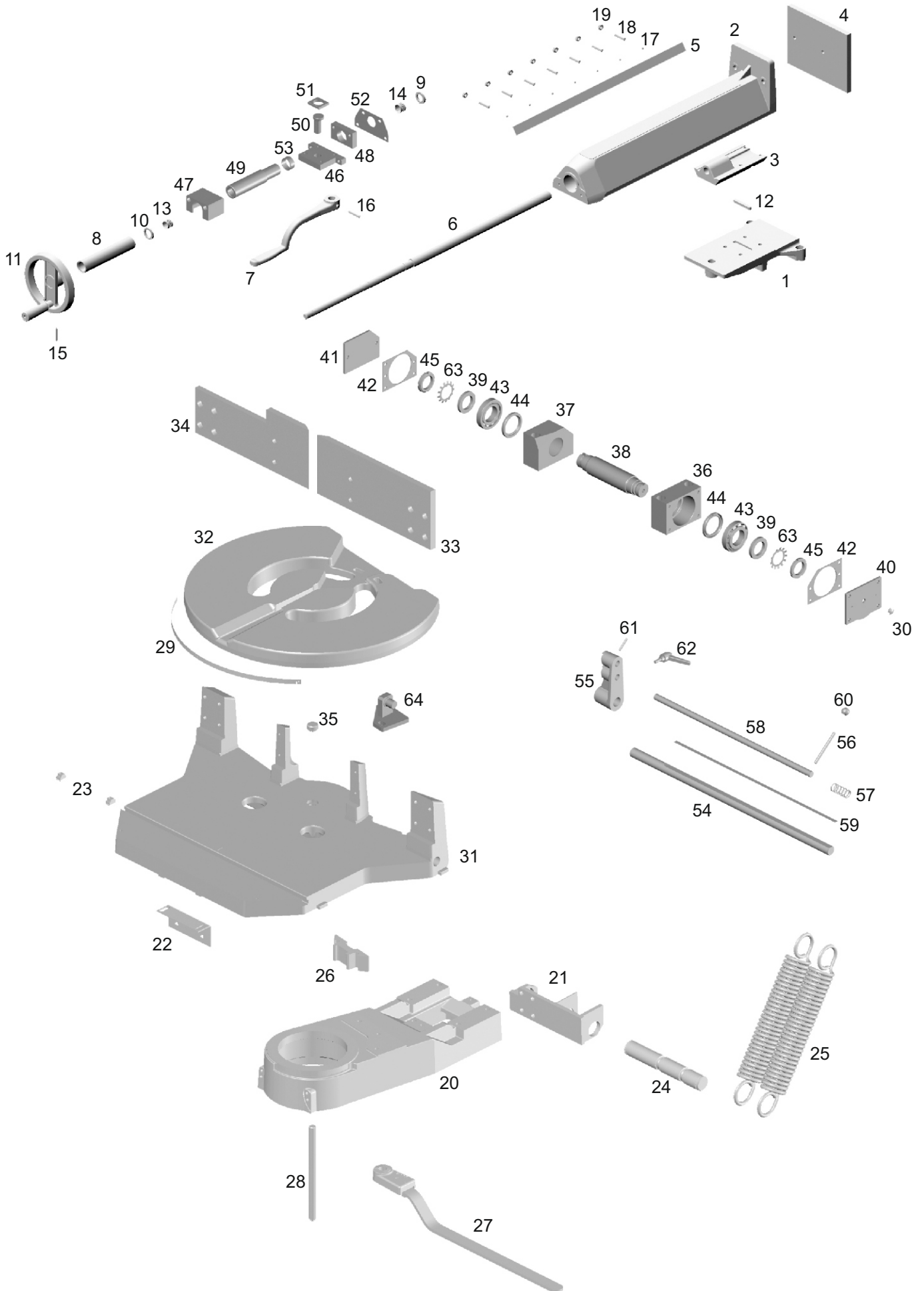



Pos	Order number	Name	Type ARG	Pcs	Pos	Order number	Name	Type ARG	Pcs
1	015394	Vice body	330+	1	33	020617	Right jaw	330+	1
2	002665	Movable jaw	330+	1	34	020616	Left jaw	330+	1
3	020623	Trapezoidal nut	330+	1	35	009603	Aligning nut	330+	1
4	020626	Movable jaw plate	330+	1	36	021574	Arm support housing	330+	1
5	002669	Groove bar	330+	1	37	022242	Arm support housing	330+	1
6	020624	Trapezoidal screw	330+	1	38	020729	Arm support shaft	330+	1
7	001357	Quick-clamping lever	330+	1	39	020728	Ring spacer	330+	2
8	020625	Retaining roller	330+	1	40	021573	Lid 3	330+	1
9	008874	Trapezoidal screw ring 1	330+	1	41	022243	Lid 4	330+	1
10	002148	Trapezoidal screw ring 2	330+	1	42	021871	Sealing	330+	2
11	002111	Vice handwheel with a crank	330+	1	43	020618	Tapered roller bearing 30209	330+	2
12	004390	Tight spring 10e7x8x60	330+	1	44	020716	Radial shaft seal 52x72x8	330+	2
13	001835	Needle bearing K18x22x17	330+	1	45	017808	KM8 Nut	330+	2
14	001836	Needle bearing K20x24x17	330+	1	46	020627	Base	330+	1
15	014238	Flexible pin	330+	1	47	020628	Enclosure	330+	1
16	009597	Flexible pin	330+	1	48	020629	Back plate	330+	1
17	001711	Ball, bearing 6	330+	7	49	020630	Tube	330+	1
18	006429	Worm Allen screw M8x35	330+	7	50	020631	Quick-clamping excentr.	330+	1
19	001712	Locking nut M8	330+	7	51	020632	Head, quick-clamping	330+	1
20	020770	Turntable	330+	1	52	020662	Washer	330+	1
21	020621	Spring pin holder	330+	1	53	004210	Enclosure	330+	1
22	021417	Vice console, upper	330+	1	54	015415	Stop rod, long	330+	1
23	001496	T Nut	330+	2	55	015416	Adjustable stop body	330+	1
24	002091	Spring pin	330+	1	56	015417	Stop rod lever	330+	1
25	001950	Tension spring	330+	2	57	015418	Compression spring 2x22x60	330+	1
26	015411	Table head	330+	1	58	015422	Stop rod, short	330+	1
27	002158	Table lever, mounted	330+	1	59	009295	Label, stop gauge	330+	1
28	020852	Screw, table, M20	330+	1	60	001552	Ball 20 M8	330+	1
29	002135	Angular plate	330+	1	61	002642	6x40 flexible pin	330+	1
30		Cap	330+	1	62	011540	Adjustable lever M8x20	330+	1
31	015397	Table plate	330+	1	63	020620	MB 8 Washer	330+	2
32	015398	Turntable	330+	1	64	014990	Hydraulics holder, lower	330+	1

## 11.5. Cleaning Brush Assembly

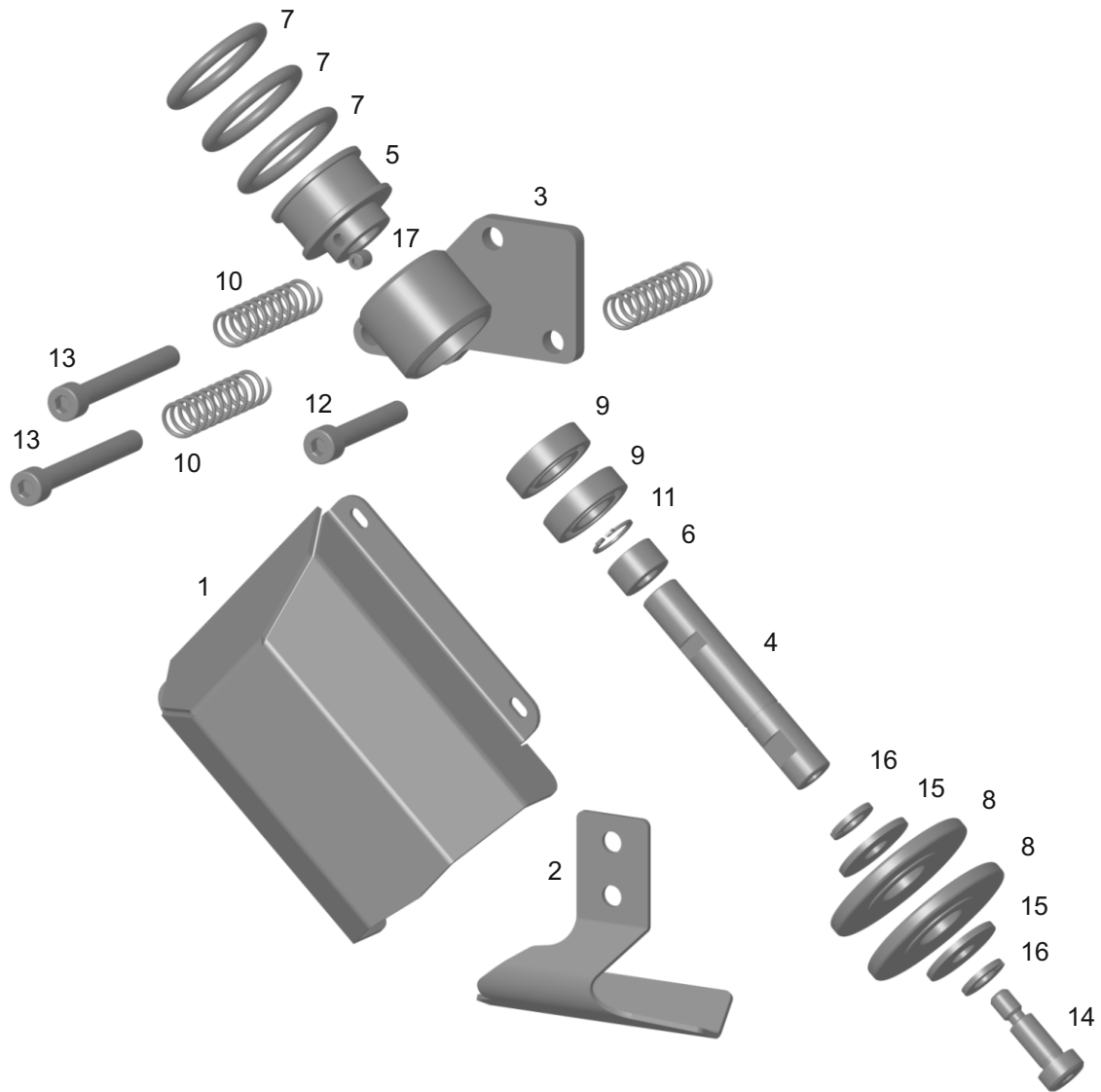

ver. 1.1.2018

Pos.	Order number	Name	Type ARG	Pcs
1	025424	Covering of brush	235	1
	025562	Covering of brush	260	1
2	025485	Covering of saw band - cube guide solid	235	1
	025566	Covering of saw band - cube guide solid	260	2
3	025416	Brush holder	235	1
	025563	Brush holder	260	1
4	025586	Shaft of brush	235	1
	025594	Shaft of brush	260	1
5	025587	Driving wheel	235,260	1
6	025588	Centering ring	235,260	1
7	025421	O-ring 35x5	235,260	3
8	004915	Brush holder	235,260	2
9	001905	Bearing	235,260	2
10	020955	Pressure ring	235,260	3
11	001430	Retaining ring external	235,260	1
12	001444	Socket screw M8x50	235,260	1
13	005104	Socket screw M8x70	235,260	2
14	025612	Hexagon fit bolt	235,260	1
15	004277	Flat washer	235,260	2
16	001581	Flexible washer	235,260	2
17	011909	Grub screw	235,260	1

## 11.6. Cooling Assembly

### 11.6.1. Cooling Assembly in ARG 200-300

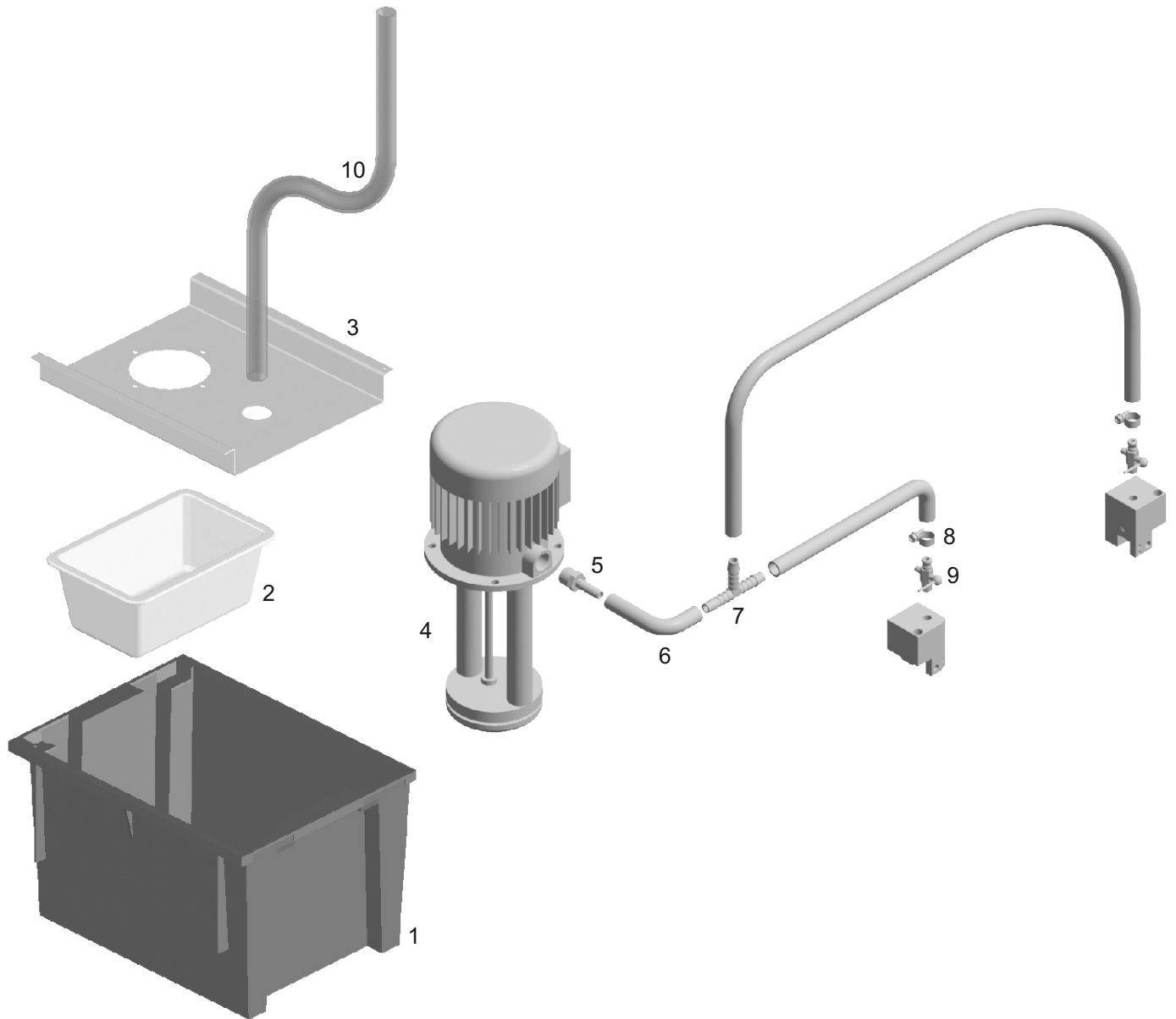

ver. 1.1.2016

Pos	Order number	Name	Type ARG	Pcs
1	001397	Coolant tank	200-300	1
2	001335	Settling container	200-300	1
3	001387	Coolant tank lid	200-300	1
4	015819	Pump 1COP1-17, 20kPa/16l/min, 3x230V/3x400V, 50Hz	200-300	1
5	002403	Hose connector, tapered, 3/4", 8 mm	200-300	1
6	001399	PVC hose DN 8x2	200,235	3,6 m
	001399	PVC hose DN 8x2	260,300	5 m
7	001401	T-piece TS 10	200-300	1
8	001398	Hose clamp	200-300	2
9	001402	Draincock 050	200-300	2
10	005747	Drain hose MPVC 25x32mm	200-300	0,7 m

### 11.6.2. Cooling Assembly in ARG 330

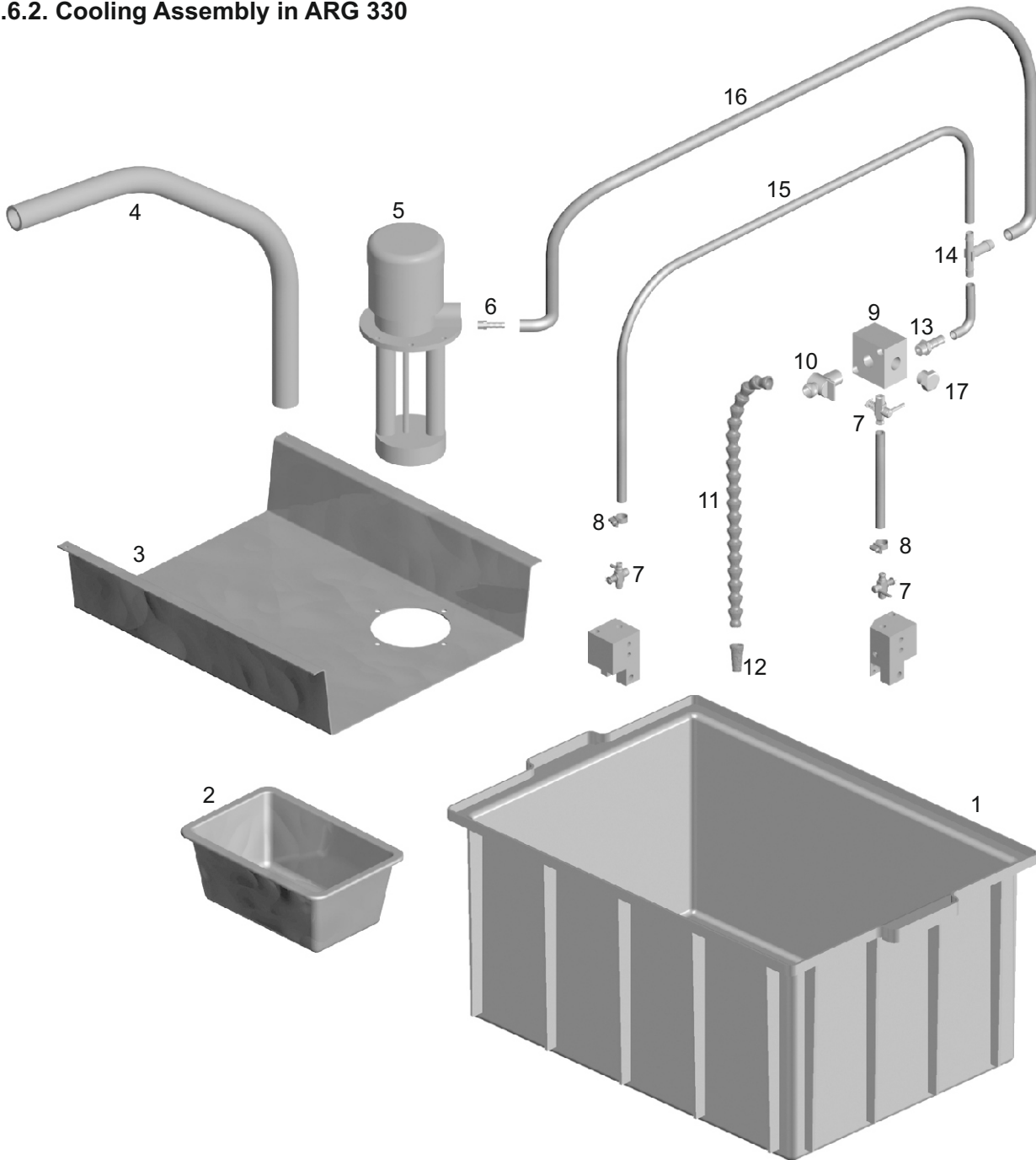

ver. 1.1.2016

Pos	Order number	Name	Type ARG	Pcs
1	001852	Coolant tank, UD crate	330	1
2	001335	Settling container	330	1
3	002274	Coolant tank lid	330	1
4	005747	Drain hose 25x320.35m	330	1
5	010155	Pump SAMEC AST 60/180	330	1
6	005458	Hose connector 1/2"x 12-13	330	1
7	001402	Drain valve	330	3
8	001398	Hose clamp 7-13	330	3
9	020311	Additional cooling head	330	1
10	020470	PT 3/8" valve	330	1
11	020403	Joint part 3/8"	330	27
12	020469	Tailpiece 3/8"	330	1
13	018941	Connector for hoses with a tapered thread 10-1/4'	330	1
14	005401	T-piece TRS 10-13-10	330	1
15	001399	DN hose 8x2 novoplast1.8m	330	1
16	021035	MPVC hose 12.5/18.5, black3.6m	330	1
17	009168	Cap	330	1

## 12. Accessories

### 12.1. Laser Guideline Light

Laser guidance is a very practical tool for easy identification of the desired length of the cut material without a horizontal side stop both during perpendicular and angular cutting. The future cutting spot is indicated by a red mark copying the saw blade.



#### Safety warning

Caution! Includes a 3R-class laser source. Avoid eye contact with both direct and reflected laser beam. Never look into the laser lens when the machine is in operation! Risk of permanent damage to your vision!

#### Information - What is a Laser of the performance class 3R - classification according to IEC 60825

To this group belong lasers that emit radiation in the continuous mode in the visible part of the spectrum, from 400 to 700 nm, and whose power does not exceed 5mW. Laser of this class cannot cause damage to the human eye in case of a fleeting glance. The eye of a healthy human is protected by the natural blink reflex, supposing the person is not under the influence of narcotic substances. It is assumed that the time that elapses between the contact with the eye and the laser beam, and the closing of the eyelids (or turning the head aside), is less than 0.25 s. That is sufficient for the retina to remain protected from the light energy of over 0.25 millijoule. The amount of 0.25 mJ is the maximum permissible value the human eye can be exposed to in case of a direct eye contact with the laser bundle. Danger arises during an intentional and a long look into the laser beam, or when contemplating the beam with an optical system. **It is not allowed to watch the beam with binoculars.** These lasers would cause permanent eye damage.

#### 12.1.1. Activation and deactivation of the laser beam

After unpacking, the laser guideline light is in a full working condition. After switching on the machine (according to the instruction manual of the machine), the laser beam is activated and starts to radiate. After turning off the machine (according to the instruction manual of the machine), the beam extinguishes.

#### 12.1.2. Laser indication on the machine

Each machine equipped with the laser guideline light must be indicated with a laser pictogram label.

In the proximity of the machine and the operator, a security warning must be displayed.



#### 12.1.3. Adjustment

If the laser beam does not point exactly at the cut, it needs to be adjusted.

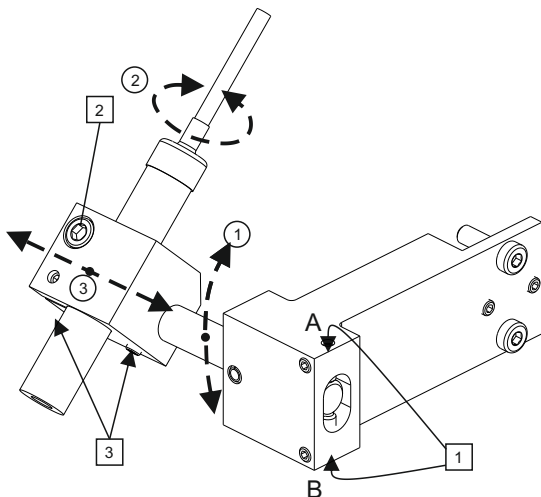

1. Switch on the machine, the laser beam starts to radiate.
2. Set up the beam as close as possible to the desired position.
3. Then, while adjusting, start moving the laser holder console ① upwards or downwards and adjust the laser beam with a descending arm so that it does not veer to one or the other side.  
If the beam veers in the direction ahead of the cut, when the shoulder is descending, loosen the setting screw 1A and tighten 1B. Or the other way round.
4. When the beam does not veer anymore and remains directed during both ascending and descending of the arm, readjust the desired direction by ② and ③.

## 12.2. Oil Mist Lubrication

When using the standard cooling equipment, coolant leakages from the machine often occur, particularly when cutting long sections. Oil mist lubrication is a device that creates oil mist subsequently applied through nozzles directly onto the saw blade that is then cooled and lubricated. The device functions by dosing oil and air mixture. It is also useful in the processing of material that excludes the contact with a regular coolant. This lubrication system is lossy, so it is necessary to refill the coolant regularly.

The injection nozzle holder must be placed near the designated point in order to reach the optimum adjustment of the nozzle with the least possible distance from the lubrication point. The supplied compressed air must be absolutely dry and oil free. Optimum operating pressure is between 4 and 8 bars. Commissioning is carried out during the open subordinate actuating valve by an external signal from the control valve (optional), the connection to mains is facilitated by a supplied screw connector (PG9). Fill the tank with COOLcut Micro liquid and the mist lubrication is ready for operation.

### Important:

In the event of use of lubricating media other than the recommended, a risk of decay or deposits arise. That is why the system functionality can only be guaranteed for the use of COOLcut Micro liquid.

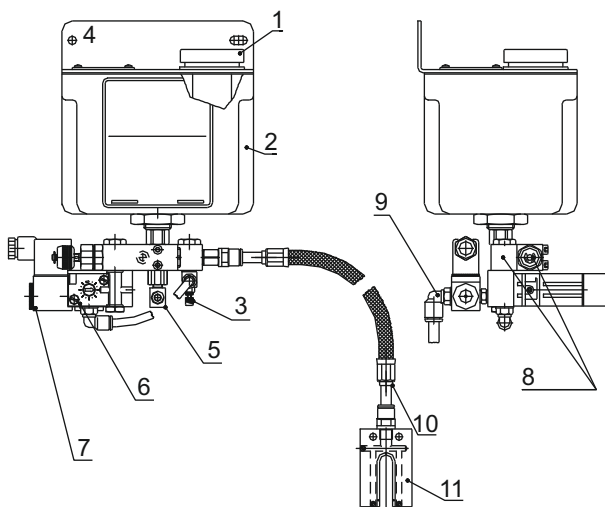

1	SCREW-ON LID WITH A FILTER
2	1.2L CONTAINER
3	OIL MIST SETTING
4	FITTING HOLE
5	VENTING
6	PULSE GENERATOR
7	SOLENOID VALVE 24V DC PG 9 SOCKET
8	DOSING PUMP
9	COUPLING 8MM
10	2.5 M COAXIAL POWER CABLE (METAL PROTECTION)
11	NOZZLE HEAD CAT. NO.: 70.107.1

### Oil mist venting

Oil mist lubrication system is supplied after testing.

Before commissioning and maintenance on the coaxial cable or nozzle, the system has to be vented. If the volume of oil in the container does not drop under the minimum threshold, other venting is not necessary.

### Venting procedure:

1. Fill the tank with a clean lubrication medium.
2. Loosen the drainage and venting screw a little and keep releasing the lubricating medium until there are no air bubbles present in it.
3. Set the pulse generator frequency to the maximum value (approx. 66 pulses per minute).
4. Set the dosing pump piston stroke to the maximum.
5. Connect the compressed air and fill the capillary tube, so that all the tubing along the whole length is bubble-free (filling duration depends on the length of tubing).
6. Connect to coaxial head to the spray head.
7. After venting, set the frequency and piston stroke to operating values again.

### Oil mist setting

1. Pulse generator settings: pneumatic time relay controls the dosing pump. You can set the frequency continuously from 0 to 66 pulses per minute.
2. Dosing pump settings: the piston vacuum pump doses the lubricating medium under high pressure. The quantity of the lubricant can be regulated by turning the manual setting wheel.
3. Oil mist spray setting: By spraying the air the drops form a very fine lubricating film and its setting influences the degree of dispersion, cooling and chips formation. Volume of air in the nozzle can be adjusted by the adjustment screw.

## DOSING PUMP SETTINGS

Piston vacuum pump doses the lubricant accurately and under high pressure.

CLICK	GROOVE No.	SUPPLIED VOLUME/STROKE
0	1	41 mm <sup>3</sup>
4	2	30 mm <sup>3</sup>
8	3	23 mm <sup>3</sup>
12	4	16 mm <sup>3</sup>
16	5	9 mm <sup>3</sup>
18	6	2 mm <sup>3</sup>
20	7	0 mm <sup>3</sup>

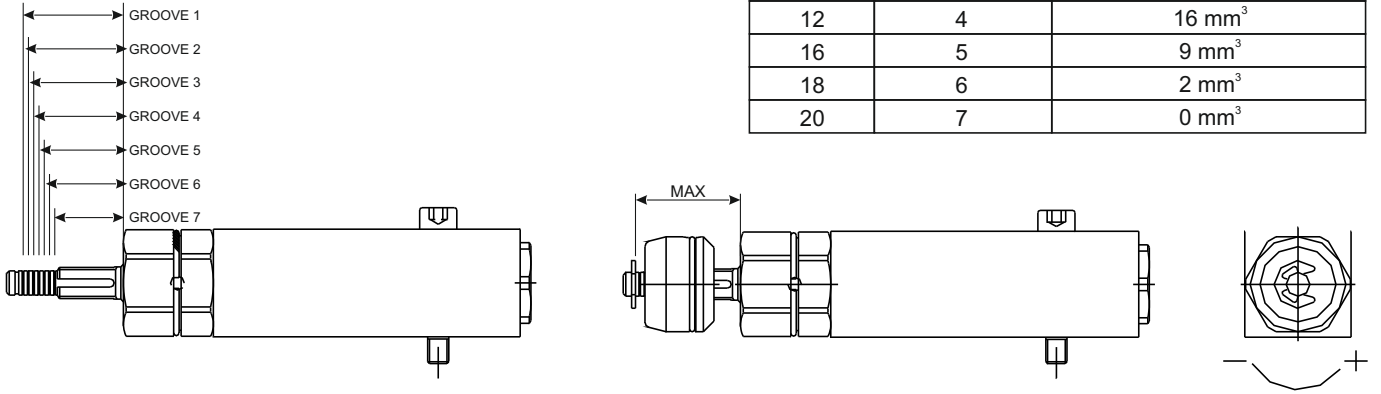

## PULSE GENERATOR SETTINGS 6 BAR (90 PSI)

66 PULSES  
PER MINUTE

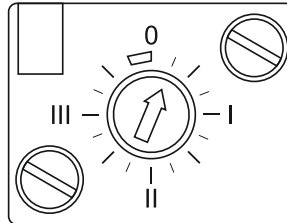

37 pulses per minute	21 pulses per minute	13 pulses per minute	10 pulses per minute	6 pulses per minute	5 pulses per minute
4 pulses per minute	3 pulses per minute	2,5 pulses per minute	2 pulses per minute	1,5 pulses per minute	1 pulses per minute

### 12.3. Vertical vice for VP bundle cutting

The vertical vice facilitates cutting of materials in bundles. Proper and sufficient clamping of all workpieces in the bundle significantly influences the service life of the saw blade. The contact pressure plate facilitates vertical clamping of the workpiece. If a larger bearing surface is required, mount your own fixture of corresponding dimensions onto the contact pressure plate. Make sure that the guide rods are locked by fixation screws before you start cutting. **Check whether the workpiece is properly clamped, otherwise you risk its ejection during cutting!**

**Caution! When using the vertical vice while cutting the workpieces in VP bundles, you can do only perpendicular cuts.**

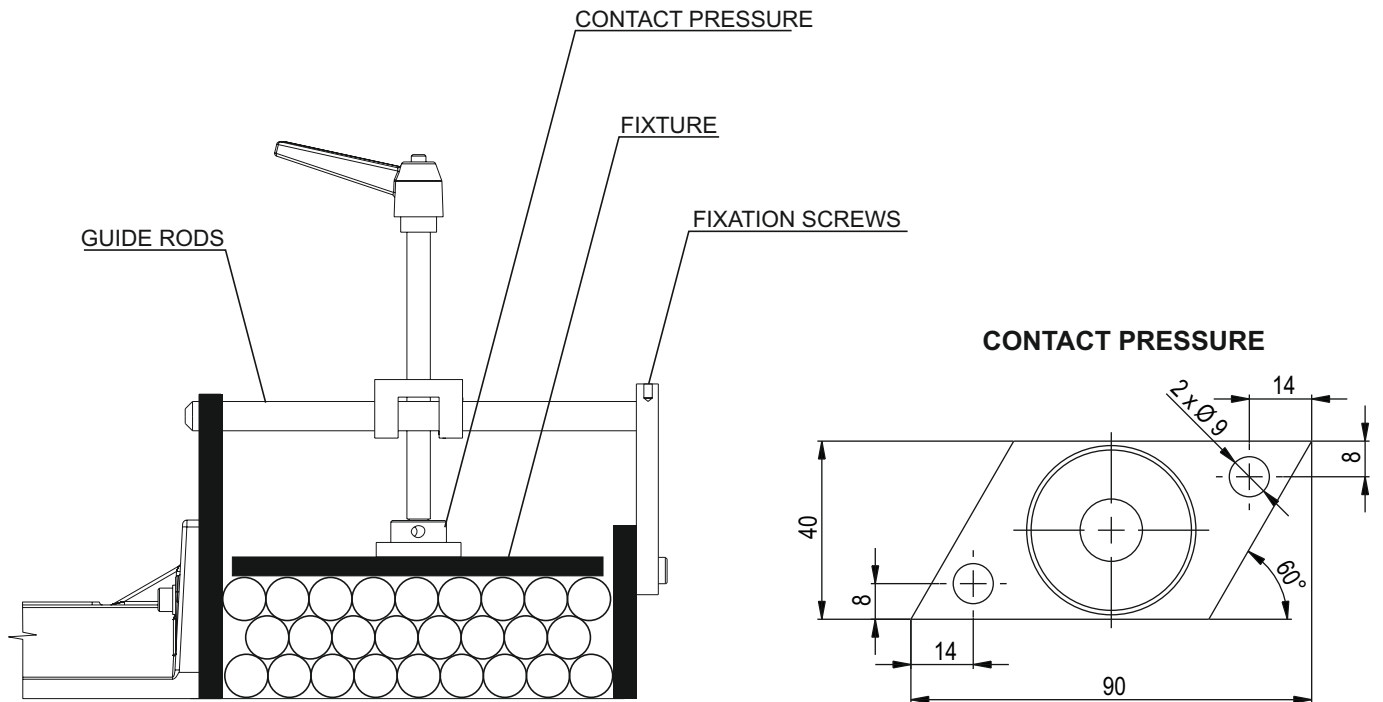

The VP packet for one-directional swing saws includes a new movable clamping jaw and also a small clamping jaw that has to be connected onto a pre-drilled cast iron fixed clamping jaw in front of the cutting line.

The VP packet for bi-directional swing saws includes a new movable clamping jaw and also a small clamping jaw that has to be connected onto a pre-drilled fixed clamping jaw in front of the cutting line.

When drilling, stabilize the vice, so that the crank does not collide when the arm is travelling upwards or downwards. Longitudinal rods are usually supplied in three pieces, in order to allow for cutting of a whole range of sections. It is necessary to replace the rod before cutting in order to prevent collision with the guide head or clamping jaw.

**UNI-DIRECTIONAL SWING**

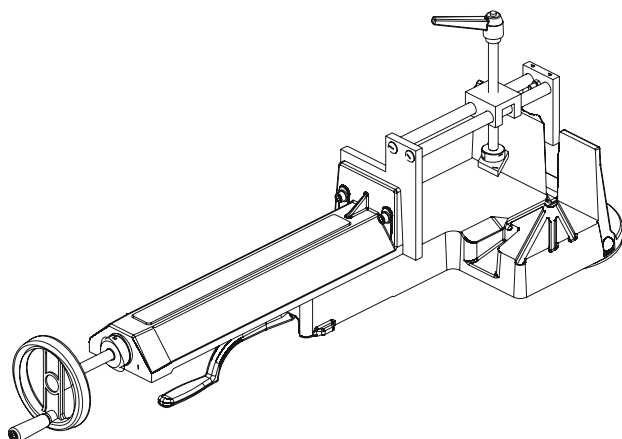

**BI-DIRECTIONAL SWING**

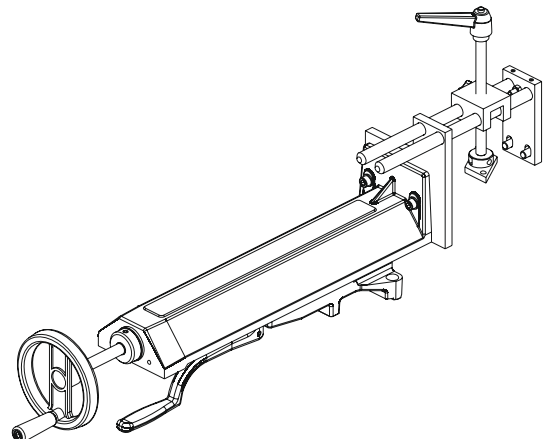



# EC Declaration of Conformity

in accordance with Directive 2006/42/EC of the European Parliament and of the Council (Government Regulation No. 176/2008 Coll.)  
in accordance with Directive 2014/35/EU of the European Parliament and of the Council (Government Regulation No. 118/2016 Coll.)  
in accordance with Directive 2014/30/EU of the European Parliament and of the Council (Government Regulation No. 117/2016 Coll.)

**Manufacturer: Pilous-pásové pily, spol. s r.o., Železná 9, Brno 619 00, CZ, VAT: CZ60727551**

**Identification data of the machine:** Band saw including accessories

**Type:** ARG 200, ARG 200 plus, ARG 235, ARG 235 plus, ARG 260, ARG 260 plus E, ARG 260 plus

**Description and designation of product function:** The band saw is intended for cutting primarily metal materials, while the workpiece is clamped in a fixed vice and the cutting is carried out by a saw blade arm.

**All applicable provisions the machine is in compliance with:**

- Directive 2006/42/EC of the European Parliament and of the Council
- Directive 2014/35/EU of the European Parliament and of the Council
- Directive 2014/30/EU of the European Parliament and of the Council

**Applied harmonized standards, national standards and technical specifications:**

- EN ISO 12100:2011
- EN ISO 14120+rev.1:2017
- EN ISO 4413:2011
- EN ISO 11202:2011
- EN ISO 3746:2011
- EN 614-1+A1:2009
- EN 16093:2017
- EN ISO 14119+rev.1:2015
- EN 60204-1 ed.2+A1+rev.1:2011
- EN 349+A1:2009
- EN ISO 13857+rev.1:2010
- EN 1037+A1:2009
- EN ISO 13849-1:2017
- EN ISO 13849-2:2013

**Person responsible for drawing up technical documentation:** Ing. Petr Mašek

name, company address: **Pilous-pásové pily, spol. s r.o., Železná 9, Brno 619 00, CZ, VAT: CZ60727551**

**Person responsible for drawing up EC Declaration of Conformity:** Ing. Petr Mašek

name, company address: **Pilous-pásové pily, spol. s r.o., Železná 9, Brno 619 00, CZ, VAT: CZ60727551**

**The manufacturer declares that the machine complies with all relevant provisions of this regulation (Directive) declares that the machine is in compliance with other regulations (Directives) which apply to the product. This declaration of conformity is issued under the sole responsibility of the manufacturer.**

**This EC Declaration of Conformity is original EC Declaration of Conformity.**

**The last two digits of the year in which the CE mark was placed on the product: 18**

**Serial number:**

In Brno, on: 1.3. 2018

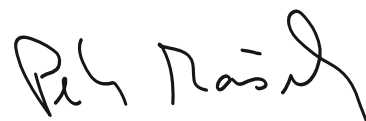

person authorized to act on our behalf  
Ing. Petr Mašek  
Managing Director

# EC Declaration of Conformity

in accordance with Directive 2006/42/EC of the European Parliament and of the Council (Government Regulation No. 176/2008 Coll.)  
in accordance with Directive 2014/35/EU of the European Parliament and of the Council (Government Regulation No. 118/2016 Coll.)  
in accordance with Directive 2014/30/EU of the European Parliament and of the Council (Government Regulation No. 117/2016 Coll.)

**Manufacturer: Pilous-pásové pily, spol. s r.o., Železná 9, Brno 619 00, CZ, VAT: CZ60727551**

**Identification data of the machine:** Band saw including accessories

**Type:** ARG 235 plus F, ARG 260 F, ARG 260 plus E.F., ARG 260 plus F, ARG 300 F, ARG 300 plus F, ARG 330 F, ARG 330 plus F

**Description and designation of product function:** The band saw is intended for cutting primarily metal materials, while the workpiece is clamped in a fixed vice and the cutting is carried out by a saw blade arm.

**All applicable provisions the machine is in compliance with:**

- Directive 2006/42/EC of the European Parliament and of the Council
- Directive 2014/35/EU of the European Parliament and of the Council
- Directive 2014/30/EU of the European Parliament and of the Council

**Applied harmonized standards, national standards and technical specifications:**

- EN ISO 12100:2011
- EN ISO 14120+rev.1:2017
- EN ISO 4413:2011
- EN 50370 - 1:2005
- EN 50370 - 2:2003
- EN 61000-6-1 ed.2:2007
- EN 61000-6-3 ed. 2 +A1+rev.1:2013
- EN ISO 11202:2011
- EN ISO 3746:2011
- EN 614-1+A1:2009
- EN 16093:2017
- EN ISO 14119+rev.1:2015
- EN 60204-1 ed.2+A1+rev.1:2011
- EN 349+A1:2009
- EN ISO 13857+rev.1:2010
- EN 1037+A1:2009
- EN ISO 13849-1:2017
- EN ISO 13849-2:2013

**Person responsible for drawing up technical documentation:** Ing. Petr Mašek

name, company address: **Pilous-pásové pily, spol. s r.o., Železná 9, Brno 619 00, CZ, VAT: CZ60727551**

**Person responsible for drawing up EC Declaration of Conformity:** Ing. Petr Mašek

name, company address: **Pilous-pásové pily, spol. s r.o., Železná 9, Brno 619 00, CZ, VAT: CZ60727551**

**The manufacturer declares that the machine complies with all relevant provisions of this regulation (Directive) declares that the machine is in compliance with other regulations (Directives) which apply to the product. This declaration of conformity is issued under the sole responsibility of the manufacturer.**

**This EC Declaration of Conformity is original EC Declaration of Conformity.**

**The last two digits of the year in which the CE mark was placed on the product: 18**

**Serial number:**

In Brno, on: 1.3. 2018

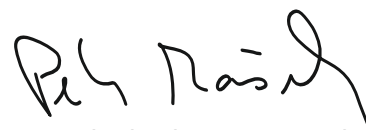

person authorized to act on our behalf  
Ing. Petr Mašek  
Managing Director

**NOTES:**

